

# **LABA7 Shock Dyno**

## **User Manual**

Lithuania 2026

## Table of Contents

1. Introduction	4
2. Safety Information	5
3. Warning Labels	6
4. Highlights	7
5. Standard package for Shock Dyno includes	8
6. Technical Specifications	8
7. Know Your Shock Dyno	10
7.1. Overview	10
7.2. Emergency Stop Button Control	12
7.3. Manual Control	12
8. Accessories	13
8.1. Adapters	13
8.2. Adapter Installation	16
9. First Launch	17
9.1. Changing the stroke	18
9.2. RFI Jumper Removal	19
10. Software Setup	23
10.1. System requirements	23
10.2. Installation	23
10.3. Configuration	24
10.4. Wireless Communication	26
10.5. USB Communication	27
11. Software Operation	28
11.1. Main Menu	28
11.2. New Project	29
11.3. Calibration	30
11.4. Creating intervals	31
11.5. Graph Comparison	34
11.6. Graphs Data Mode Graph Types	35
11.7. Channels Data Mode Graph Types	43
11.8. Graph Tools	45
11.9. Additional Test Options	46
11.10. Open existing project	48
11.11. Test summary	49
11.12. Settings	51
11.13. Reporting	54
11.14. Data Export and Import	57
11.15. LABA7 manufacturing mode	59
12. DAQ configuration	66
13. Electrical wiring	69

14. Troubleshooting	70
14.1. General	70
14.2. Wi-Fi Configuration	70
14.3. Wi-Fi Operation	71
14.4. USB Configuration	71
14.5. USB Operation	72
14.6. Mechanical Failures	72
14.7. LED Light Indicator	73
15. Additional information	74
16. Speed to load table	75
17. Warranty Information	77
18. Contact	78
19. EU declaration of conformity	79

## **1. Introduction**

Dear Customer,

Thank you for purchasing this product.

To ensure this condition and ensure safe operation, you must observe these operating instructions!

Read the entire operating instructions before using the machine for the first time. Observe all operating instructions and safety instructions!

All company names and product names are trademarks of their respective owners. All rights reserved.

**UAB LABA7**

**Address:** Giluzio st. 15 Vilnius LT-06253 Lithuania





**Email:** info@laba7.com

**Mobile phone:** +37065715336

## 2. Safety Information

- This manual is designed to be used in conjunction with the service manual and documentation provided by the shock absorber's manufacturer.
- Make sure to read and understand the whole user manual before using the Shock Dyno (further – device).
- The device works under excessive force, therefore, wear protective eyewear and take all cautions required to work in a safe environment.
- Connect the Shock Dyno to a grounded power socket.
- Only use the electric cord provided with the device.
- Do not use the power cord if it is pinched, sheared or cut.
- Do not use any power adapters if the plug doesn't fit your wall socket.
- Do not use an extension cord.
- The power socket to which you are connecting the Shock Dyno needs to be easily accessible to be able to unplug it in an emergency easily.
- Do not operate nearby an open flame or heat source.
- Place on a flat and level surface.
- Do not place in a highly corrosive or humid environment.
- Do not use the device or any of its components if they have been damaged.
- Do not perform any maintenance while the device is plugged into the mains.
- Make sure that the safety doors are closed adequately before running a test.
- Do not open or tamper with the safety lid or any other machinery parts during live operation.

### 3. Warning Labels

Warning Label	Explanation
	<p>Warning – Crushing of Hands (ISO 7010-W024)</p> <p>This safety symbol indicates a potential crushing or pinch hazard to hands from the closing or moving parts of the equipment. It alerts users to keep hands and fingers clear of these areas to avoid serious injury.</p>
	<p>Warning – Electricity (ISO 7010-W012)</p> <p>This safety symbol indicates a potential electrical hazard. It alerts users that electrical components, voltages, or currents are present that could cause electric shock or injury. Users should take appropriate precautions, avoid contact with exposed electrical parts.</p>
	<p>Prohibition – Not to Be Serviced by Users (ISO 7010-P069)</p> <p>This safety symbol indicates that the equipment must not be opened, adjusted, maintained, or serviced by users. It informs users that only qualified or authorized personnel should perform servicing, repair, or internal inspection to avoid risk of injury, electric shock, damage to the equipment, or other hazards.</p>
	<p>Emergency – Emergency Stop (ISO 7010-E020)</p> <p>This safety indicates the location of an emergency stop device. It identifies a control that is intended to stop the equipment immediately in an emergency situation to reduce the risk of injury, damage, or hazardous conditions.</p>

### 4. Highlights

Congratulations on your purchase of the LABA7 Shock Dyno!

- Our fully automatic dynamometer allows you to test the mechanical force transmitted through any shock absorber as well as measure a multitude of variable factors pertaining to velocity, displacement, and other impacts, such as bump stops. It does not matter which discipline you are working with – MTB, Motorcycles, Cars, 4X4, ATVs – all shocks can be tested. This machine is straightforward to use, and you can get the most accurate results immediately on your complimentary software/monitoring app.
- Shock absorber testing – Check if you have the right shock for the right use case or performance. Additionally, you can test whether the same shock is being kept throughout the travel. The device can also be used to compare two different shock absorbers.
- Test bump stops – Check the shock rate of your bump stops to develop an accurate quality estimate of different factors such as suspension sag, body roll, and cushioning for the driver.
- Parts tested – Empty shocks/Shocks with springs/Forks with springs/Forks with air springs/Bump stops.
- High-accuracy force/pressure sensors.

## 5. Standard package for Shock Dyno includes

- Scotch-Yoke Shock Dyno unit.
- Power cable (EU or USA plug variant).
- USB communication cable.
- Shock absorber safety plates.
- 2x standard U-clamp adapters.
- User manual (available for download on our website).
- Software (free download from our website).
- Customer support via email / WhatsApp.

## 6. Technical Specifications

Below are the specifications of each individual Shock Dyno model:

### **Featherlight Shock Dyno:**

- Speed 8 - 1900mm/s
- 10000N load cell
- Adjustable stroke 25 - 100mm
- 3HP-230V electric motor (110V available on request).
- Scotch-yoke system for accurate linear motion
- Mast length 130cm

### **Light Shock Dyno:**

- Speed 7 - 2600mm/s
- 10000N load cell
- Adjustable stroke 25 - 150mm
- 4HP-230V electric motor (110V available on request).
- Scotch-yoke system for accurate linear motion
- Mast length 130cm

### **Mid Shock Dyno:**

- Speed 7 - 2600mm/s
- 15000N load cell
- Adjustable stroke 25 - 150mm
- 5HP-380V electric motor
- Scotch-yoke system for accurate linear motion
- Mast length 130cm

### **Heavy Shock Dyno:**

- Speed 8 - 3000mm/s
- 15000N load cell
- Adjustable stroke 25 - 150mm
- 10HP-380V electric motor
- Scotch-yoke system for accurate linear motion
- Mast length 130cm

### **Super Heavy Shock Dyno:**

- Speed 8 - 3000mm/s
- 20000N load cell
- Adjustable stroke 25 - 150mm
- 15HP-380V electric motor
- Scotch-yoke system for accurate linear motion
- Mast length 130cm

## 7. Know Your Shock Dyno

### 7.1. Overview

The overview of the LABA7 Shock Dyno Feather and Light models is presented in the image (Figure 1) below:

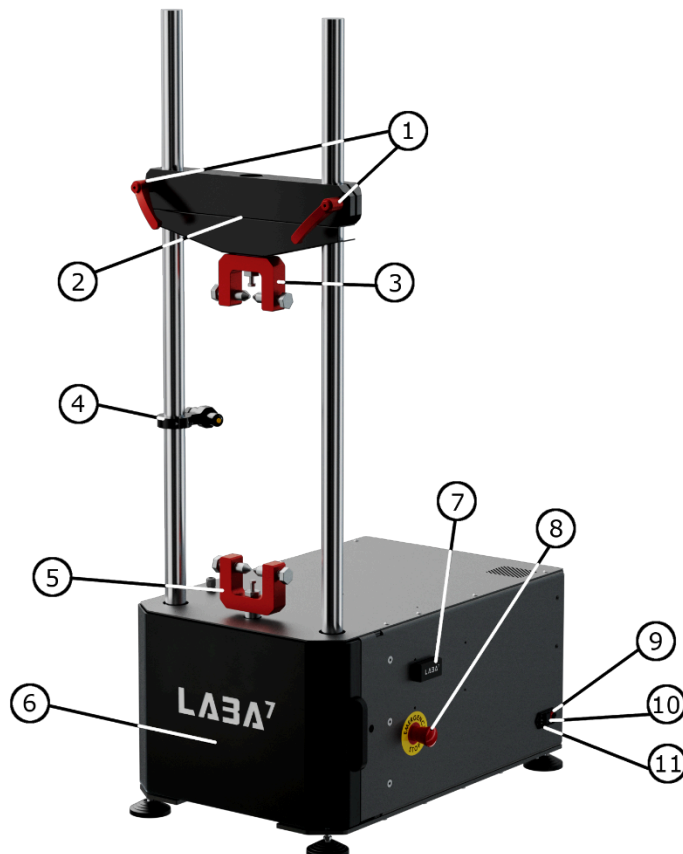

Figure 1

- |                             |                            |
|-----------------------------|----------------------------|
| 1. Crossbar handles.        | 7. USB connector.          |
| 2. Preload crossbar.        | 8. Emergency stop button.  |
| 3. Top mounting bracket.    | 9. Power switch.           |
| 4. Temperature sensor.      | 10. Fuse.                  |
| 5. Bottom mounting bracket. | 11. Power cable connector. |
| 6. Safety cover.            |                            |

The overview of the LABA7 Shock Dyno Mid and Heavy models is presented in the image (Figure 2) below:

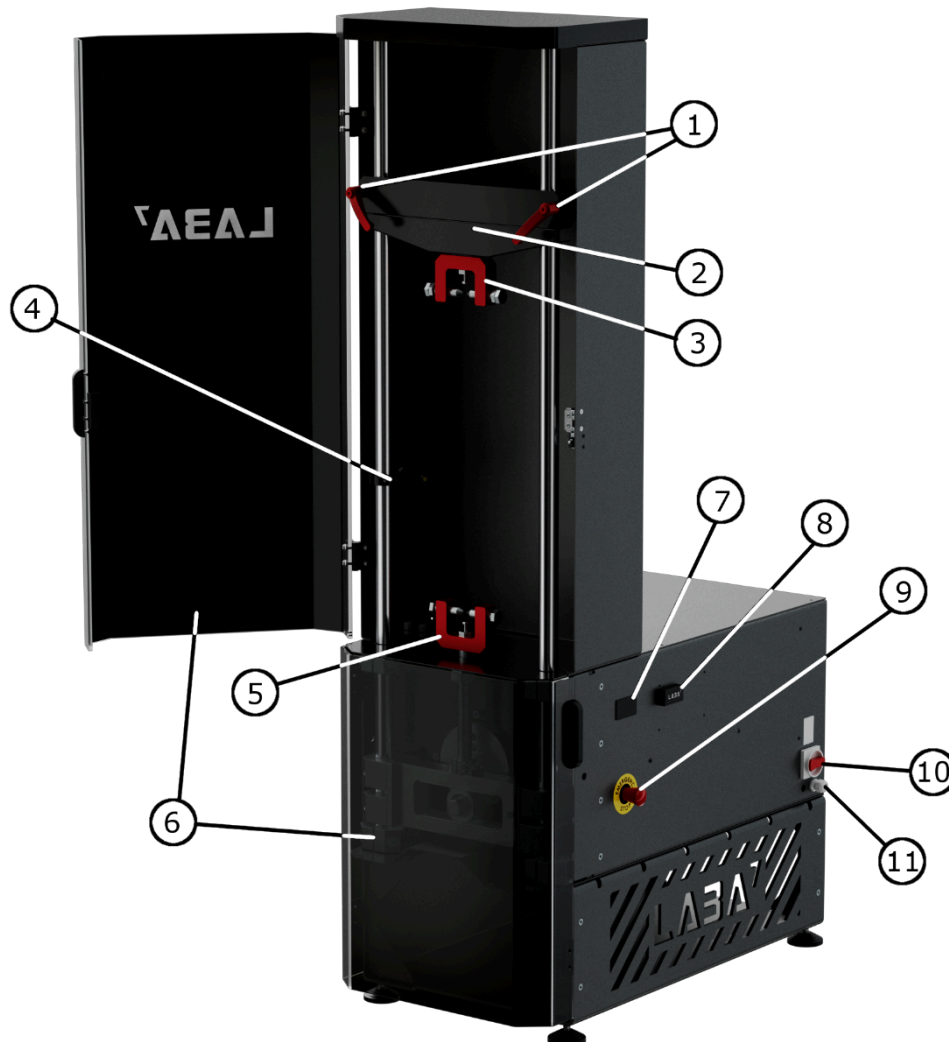

Figure 2

- |                             |                            |
|-----------------------------|----------------------------|
| 1. Crossbar handles.        | 7. Manual Dyno controller. |
| 2. Preload crossbar.        | 8. USB connector.          |
| 3. Top mounting bracket.    | 9. Emergency stop button.  |
| 4. Temperature sensor.      | 10. Power switch.          |
| 5. Bottom mounting bracket. | 11. Power cable.           |
| 6. Safety covers.           |                            |

## 7.2. Emergency Stop Button Control

The Emergency Stop button can be activated anytime during operation. To activate the emergency button:

1. Press the button to stop any operation.
2. Rotate the Emergency Stop button to the right to release it and deactivate the emergency state.

## 7.3. Manual Control

Shock Dyno Mid and Heavy models can be controlled via a manual dyno controller:

1. Adjust the motor frequency by rotating the knob on the manual display.
2. Press the RUN button to start the Dyno.
3. Motor frequency can be adjusted while the Dyno is running.
4. Press the STOP button to stop the Dyno.



**ATTENTION:** Use the emergency stop button to engage the safety mechanism before opening the protective lid or removing shocks or forks to disable the Dyno from running by accident and prevent the risk of injury.

## 8. Accessories

### 8.1. Adapters

Here you will find various adapters compatible with the Shock Dyno.

#### Universal Clamp Assembly

- Fits many different shock absorbers
- 74mm clearance
- Can be used for both top and bottom mount
- 3-way locking bolts for extra stiffness



Figure 3

#### Self-Preload Assembly

- Fits shock absorbers with the external gas chamber
- 30mm clearance
- Easy preload mechanism
- Can be used together with a universal clamp
- 9.8mm mounting axis



Figure 4

### Moto Fork Assembly

- One or two forks can be tested
- Adjustable offset
- Fits 20mm and 26mm axles
- Standard axle mount
- Stock inserts 54mm and 56mm
- Different size inserts on request



Figure 5

### MTB Fork Assembly

- Fits steerer tube of 28.6mm
- Adjustable offset
- Fits 20mm and 26mm axles
- Standard axle mount
- Fits universal clamp



Figure 6

## MTB Cartridge Assembly

- Fits universal clamp
- Fox 34/36/40 adapters
- Öhlins 36/38 adapters
- RockShox adapters
- Different size adapters on request



Figure 7

## Trunnion Assembly

- Fits Trunnion shock absorbers
- Can be used with self-preload clevis
- Automatic alignment
- 2 locking bolts for extra stiffness



Figure 8

## 8.2. Adapter Installation

Whenever installing a new adapter into the Dyno or replacing an existing one, follow the steps below:

1. Make sure the Shock Dyno is powered off, or the Emergency Stop Button is engaged before changing the adapters.
2. Use a wrench tool to unscrew both vertical bolts to release the clamp heads. (Figure 9 – Step 1)
3. Switch to another adapter and use the same method to secure the bolts in place.
4. Release the Emergency Stop Button if previously engaged.

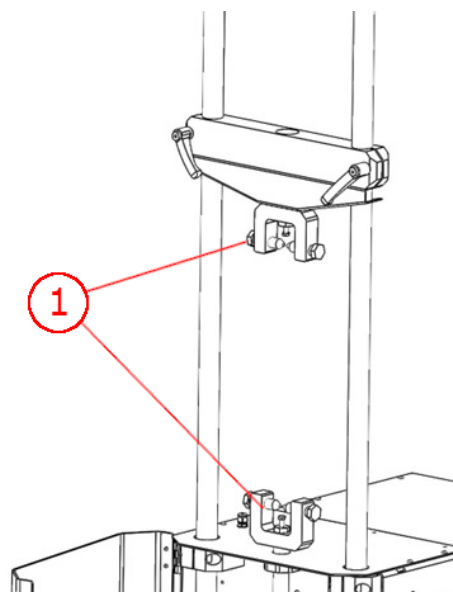

Figure 9

### 9. First Launch

This section provides information associated with the first use of the LABA7 Shock Dyno.

Follow the steps below to launch the Shock Dyno for the first time:

1. Plug the power cable provided with the device into the power connector and plug into the mains.
2. Turn the Shock power switch on. The green light on the switch will light up, or the manual dyno controller will light up.
3. If powering on the Shock Dyno results in the shortening of an earth leakage circuit breaker, follow the instructions of RFI Jumper Removal (Section 7.2) to solve the issue.
4. Press the Emergency Stop Button to disengage the Shock Dyno before mounting the damper.
5. Open the safety doors by pulling from the cover side handle.
6. Place the damper within the top or bottom adapter and secure it.
7. Adjust the handles of a preload crossbar and lower or raise it to align the damper with the other unsecured adapter and secure it in place.
8. Before tightening the preload crossbar, ensure the dyno mast is in its dead-bottom position (use a socket or spanner wrench to adjust the motor so it is placed bottom-wise during the start of rotation).
9. If your damper requires a different stroke on the Shock Dyno, follow Changing the Stroke (Section 7.1) instructions.
10. Preload the crossbar by pushing it downwards and tightening the handlebars.
11. Release the Emergency Stop Button.
12. Power off the Shock Dyno to configure the software.

## 9.1. Changing the stroke

Follow the steps below to change the stroke on the Shock Dyno. These steps apply to all the Shock Dyno models.

1. Press the Emergency Stop Button to disengage the Shock Dyno and prevent the motor from moving.
2. Rotate the roller bolt using a wrench (Figure 10 – Step 1) and insert the locking pin to lock the roller in place (Figure 10 – Step 2).
3. Unscrew the rolling bolt until it is loose.
4. Slide the roller to the side to mount it into a different hole on the flywheel.
5. Tighten the bolt to 75 Nm  $\pm$ 5 Nm.
6. Remove the locking pin to complete the stroke adjustment.

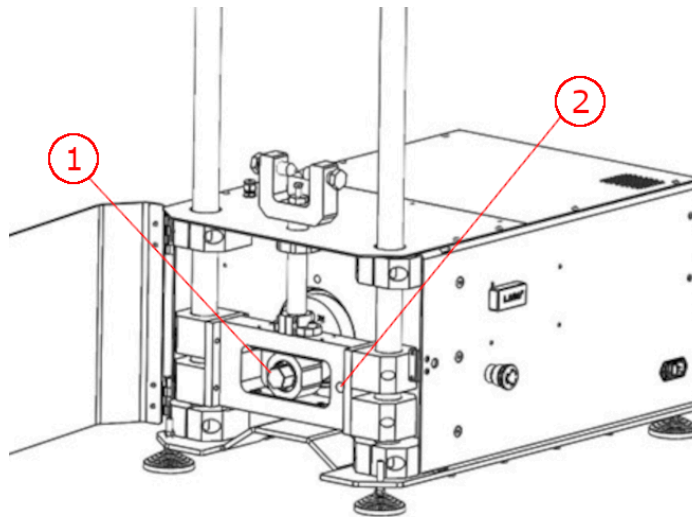

Figure 10

## 9.2. RFI Jumper Removal

If a power system that powers the Dyno has an earth leakage circuit breaker (RCBO), with the power on, it can break. In such cases, an RFI jumper must be removed from inside the Dyno.

The purpose of using the RFI jumper is to isolate the main power from the ground. If the AC motor drive is supplied from an IT or TN power system, the RFI jumper must be removed. This disconnects the RFI capacities (filter capacitors) from the ground to prevent circuit damage and reduce current leakage to the ground.

RFI Jumper is located on the AC Motor Driver:



*Figure 11*

This guide applies to all models of LABA7 Shock Dyno; however, there are two possible modifications of the AC Motor driver. This can result in a different RFI jumper, nonetheless the location and steps to remove it are similar.

The motor driver can be found inside the Shock Dyno. Remove the top cover using 4-6 screws (depending on the different Shock Dyno model).

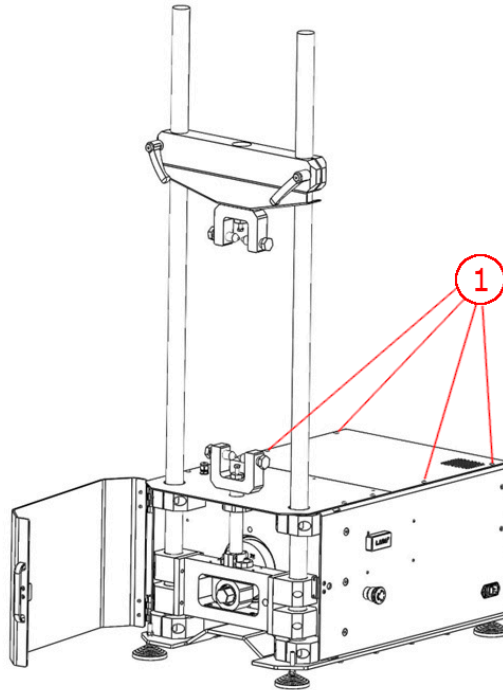

*Figure 12*

Once the cover is open, you should see the AC Motor driver on the side of the Dyno towards the back, next to the motor.

It is likely that the RFI pin (jumper) is located on the left side of the AC Driver. In that case, you will have to remove the 2 screws from the side of the Dyno that hold the plate on which the AC Driver is mounted.

**Configuration 1:**

The RFI jumper is on the side of the AC Driver and is held by a bolt.

To remove the RFI jumper, release the bolt holding the jumper. Remove the jumper. Tighten the bolt back.

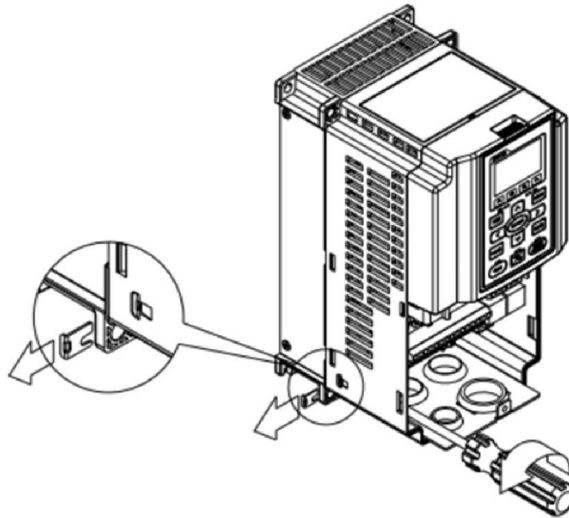
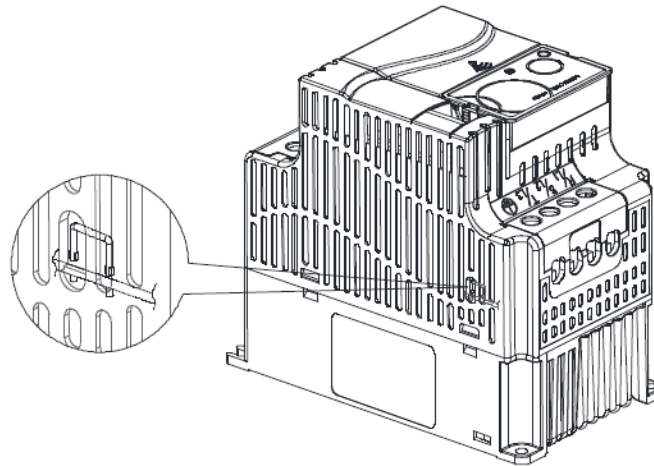

*Figure 13*

Assemble everything back and close the Dyno cover before powering on the device.

**Configuration 2:**

The RFI jumper is on the side of the AC Driver in a small hole. It looks like a small wire. To remove the RFI jumper, use pliers to cut the wire or pull it out.



*Figure 14*

Assemble everything back and close the Dyno cover before powering on the device.

In case of any other questions regarding the wiring, please get in touch with LABA7 team.

## 10. Software Setup

### 10.1. System requirements

These are the minimum requirements for the app to function in conjunction with Dyno:

- Windows 8, 10, 11
- .NET CORE 8.0
- 4 GB of RAM
- 1 GB of free disk space

### 10.2. Installation

Contact LABA7 support to receive the latest Shock Dyno software version.

1. Open the Shock Dyno software folder.
2. Locate the “LABA7-win-Setup.exe” executable file and double-click to run the installation.
3. Setup will install the program and automatically launch the software once the installation is done (a shortcut will be created on your desktop).

Alternative installation method

1. Open the Shock Dyno software folder.
2. In the file path bar at the top of the window, type “cmd” (without quotation marks) and press Enter.
3. In the Command Prompt window that appears, paste the following command and press Enter: LABA7-win-Setup.exe --installto "C:\Users\Public\Documents\Shock Dyno Software"  
**Note:** You can change the path inside the quotation marks to any desired installation directory
4. The installation will begin, software will be installed to the specified location, after installation the software will automatically launch the software (a shortcut will be created on your desktop).

## 10.3. Configuration

After launching the application for the very first time, follow the steps below to configure the initial settings:

1. Keep the Dyno powered off.
2. Launch the application and go to the Settings page which is located in the top right corner.

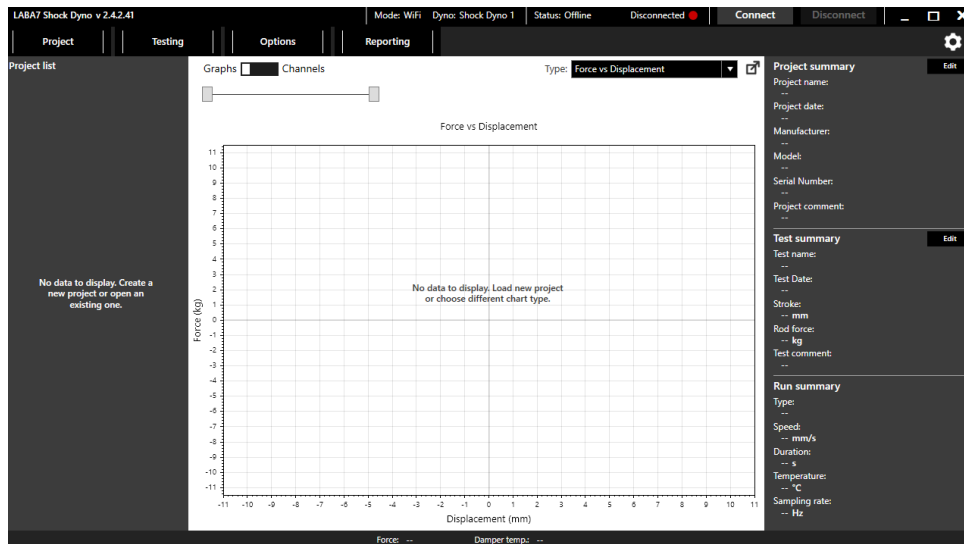

Figure 15

3. Select the default data catalog, default reports catalog and default preset catalog, these are the catalogs, where all of your test project files, reports and presets will be saved (Figure 16 – Step 1, Step 2, Step 3).

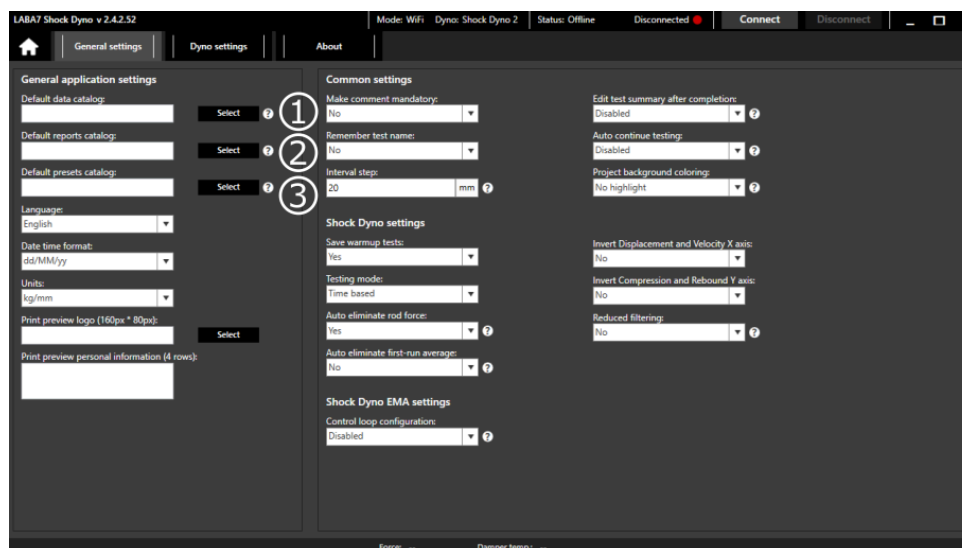

Figure 16

4. Go to the Dyno Settings tab.
5. Add a new Dyno model by clicking Add button (Figure 17 – Step 1).

- a. You can rename the model by double-clicking on the model's name in the Dyno list.
- b. Multiple models are used to switch between them during the operation quickly.

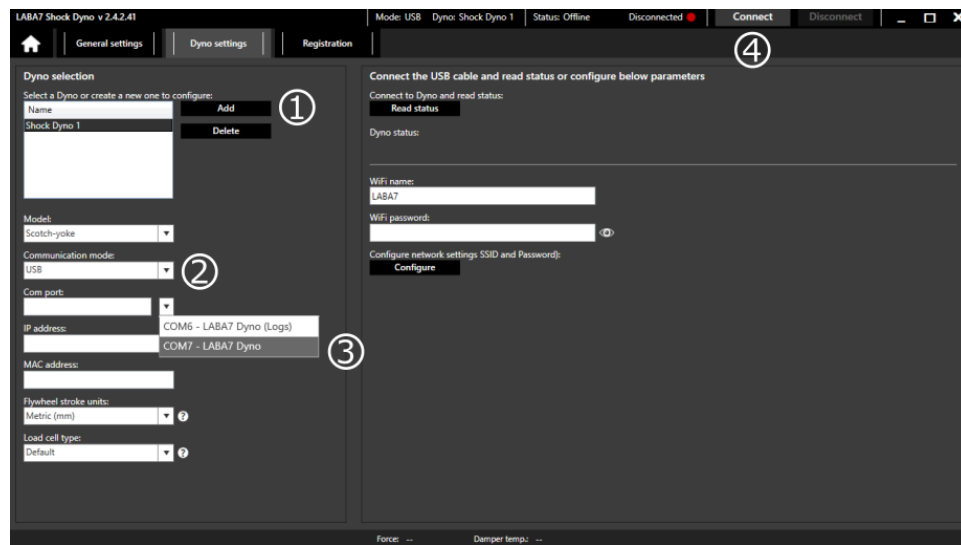

Figure 17

6. Turn on the Dyno if it was previously turned off.
7. Select Communication Mode by clicking on the drop-down menu (Figure 17 – Step 2):
  - a) Wireless communication—Wi-Fi network is required in the workshop (no LAN connection is needed). Make sure the router is relatively close to the Dyno, and there are no obstacles to cause interference to the signal
  - b) USB cable—the cable will have to be connected at all times during operation with the Dyno
8. Connect the USB cable to the LABA7 Dyno and the computer.
9. Wait 15-20 seconds for the Dyno to initialize.
10. From 2 newly appeared com-ports select **COM7 - LABA7 Dyno** .(Figure 17 – Step 3).
11. Press Connect (Figure 17 – Step 4).



**ATTENTION:** Based on your preference, go to the next section for either wireless or USB communication setup.

## 10.4. Wireless Communication

This section indicates how to set up wireless communication between the Dyno and the computer. The following items should be considered when choosing this communication type:

- Up-to-date Wireless Router in the workshop to ensure a stable and fast connection for data transfer during the Dyno operation.
- Open area for a Dyno to operate with a router placed in a line-of-sight from the Dyno. Any object between the Dyno and the wireless router can negatively impact the wireless signal, resulting in poor signal quality.

Follow the steps below to configure the wireless communication:

1. Turn on the Shock Dyno.
2. Launch the application and go to the Settings page.
3. Go to the Dyno Settings tab.
4. Connect the USB cable to the LABA7 Dyno and to the computer.
5. Wait 15-20 seconds for Dyno to initialize.
6. Press “add” (Figure 18 – Step 1).
7. Select USB communication mode (Figure 18 – Step 2).
8. From 2 newly appeared com-ports select **COM7 - LABA7 Dyno** (Figure 18 – Step 3).
9. Press “Connect” (Figure 18 – Step 4).
10. Enter Wi-Fi name and password into the corresponding fields (Figure 18 – Step 5).
11. Click on Configure button (Figure 18 – Step 6).
12. After successful configuration press “disconnect” (Figure 18 – Step 7).
13. Go back to step 2 and change the communication mode to “wireless”.
14. Press “connect” again (Figure 18 – Step 4).

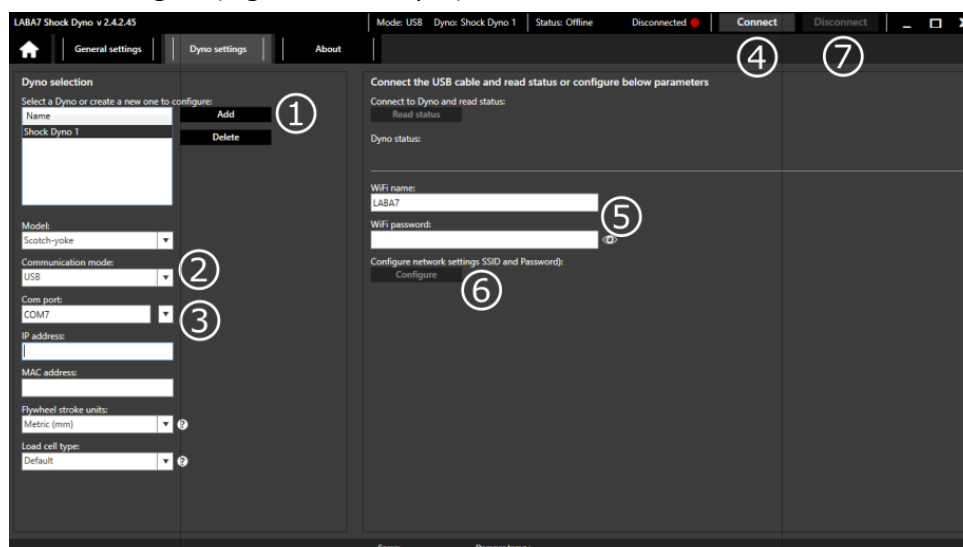

Figure 18

After a successful connection to the router, Dyno status should indicate connected to WIFI with a green indicator in the upper right application corner.



**ATTENTION:** If any of the steps fail or the Dyno is still not connected to the application, go to the troubleshooting section.

## 10.5. USB Communication

This section indicates how to set up a USB communication between the Dyno and a computer. Follow the steps below to configure the USB communication:

1. Turn on the Shock Dyno.
2. Launch the application and go to the Settings page.
3. Go to the Dyno Settings tab.
4. Connect the USB cable to the LABA7 Dyno and to the computer.
5. Wait 15-20 seconds for the Dyno to initialize.
6. Press “add” (Figure 19 – Step 1).
7. Select the USB communication mode (Figure 19 – step 2).
8. From 2 newly appeared com-ports select **COM6 - LABA7 Dyno** (Figure 19 – Step 3).
9. Press “connect” (Figure 19 – step 4).
10. Check the USB icon in the top right corner, it should be green.

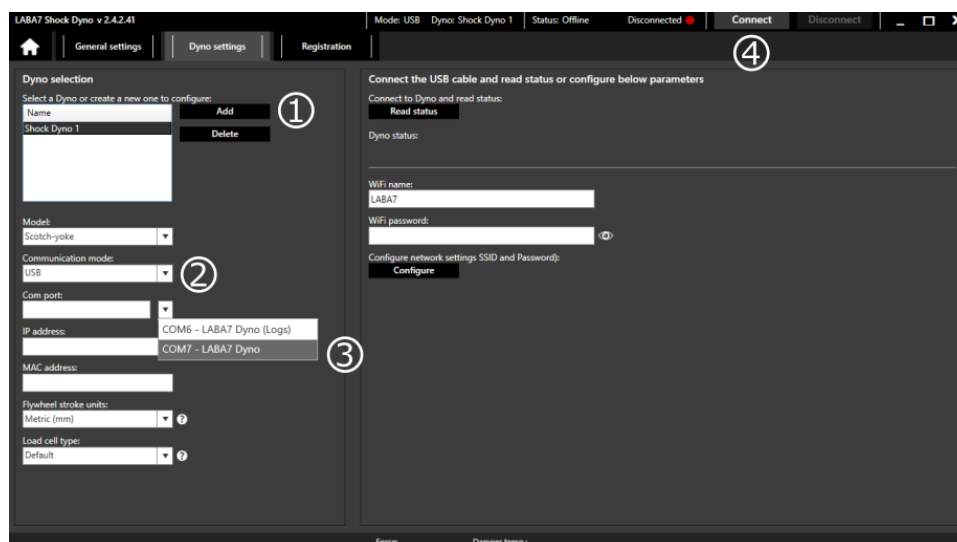

Figure 19



**ATTENTION:** If any of the steps fail or the Dyno is still not connected to the application, go to the troubleshooting section.

## 11. Software Operation

### 11.1. Main Menu

Once the application is launched, you will see the main screen with 5 separate buttons:

- Project – create new, open old projects and tests, import .csv.
- Testing – for new test configuration and execution.
- Options – visualization tools, test presets and other additional functionalities.
- Reporting – for report printing and data exporting.
- Settings – software and hardware configuration.

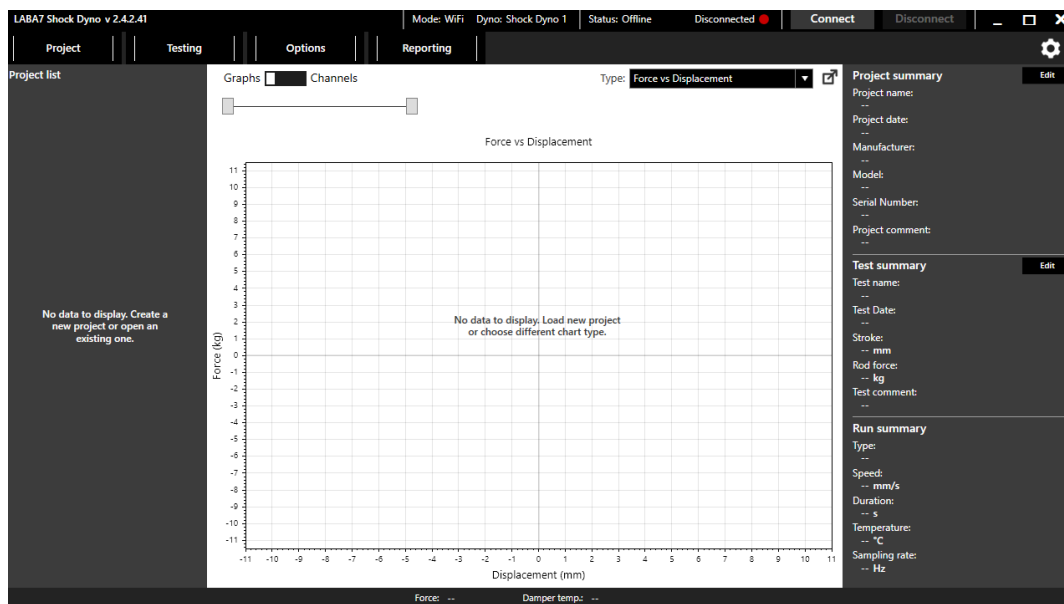

Figure 20

Additionally, you can check your software version, edit project summary, edit test summary, check Live dyno data such as temperature and current force. You can see which dyno is active and what communication method is being used as well.

## 11.2. New Project

Whenever a new damper is inserted into the Dyno, it is recommended to start a New Project. Locate “project” button in the top left corner, press it and then – press “new project”.

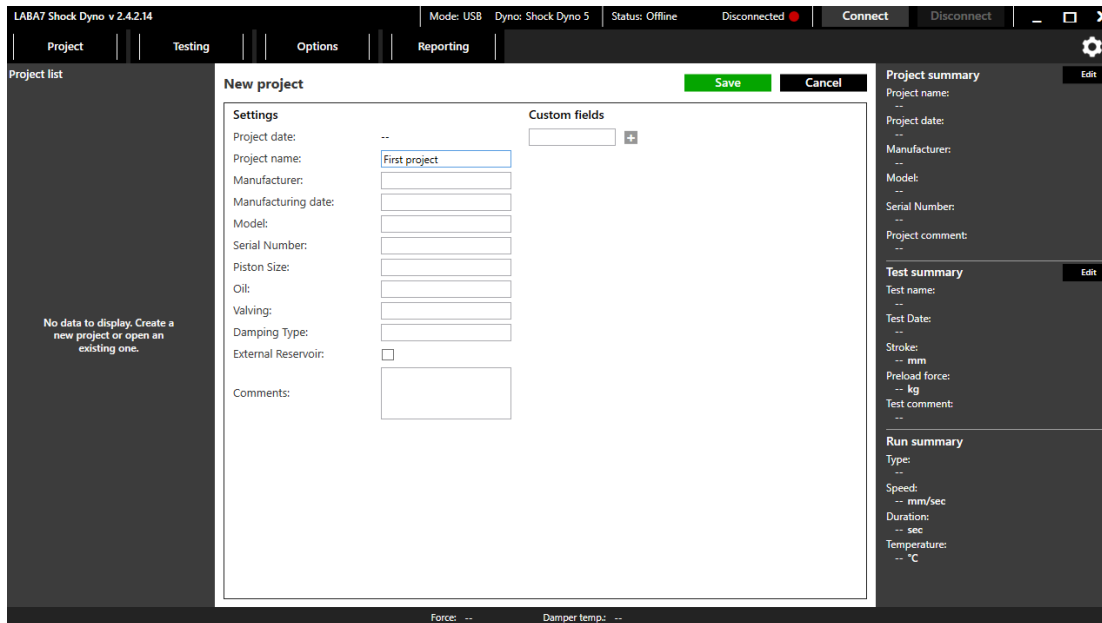

Figure 21

Enter the following information to proceed to the testing area:

- Project Name – the name of the project that will be tied to all the tests within this project.
- Manufacturer – manufacturer of the damper being tested.
- Manufacturing date – the date when the damper was manufactured.
- Model – model name of the damper which is being tested.
- Piston size – the size of the damper’s piston.
- Oil – oil type which is being used in the damper.
- Valving – valving type of the damper which is being tested.
- Damping type – the damping type of the damper which is being tested.
- External reservoir – select if the damper has an external reservoir.
- Comment – comment about a project.
- Custom fields – allow you to create your own data fields to suit specific project needs.

After all needed info is entered, press .

## 11.3. Calibration

This section describes the calibration process of the dyno.

After the damper is installed and the project is created, dyno needs to be calibrated. To do this, locate the “testing” button in the top, you will see a window shown in Figure 22.

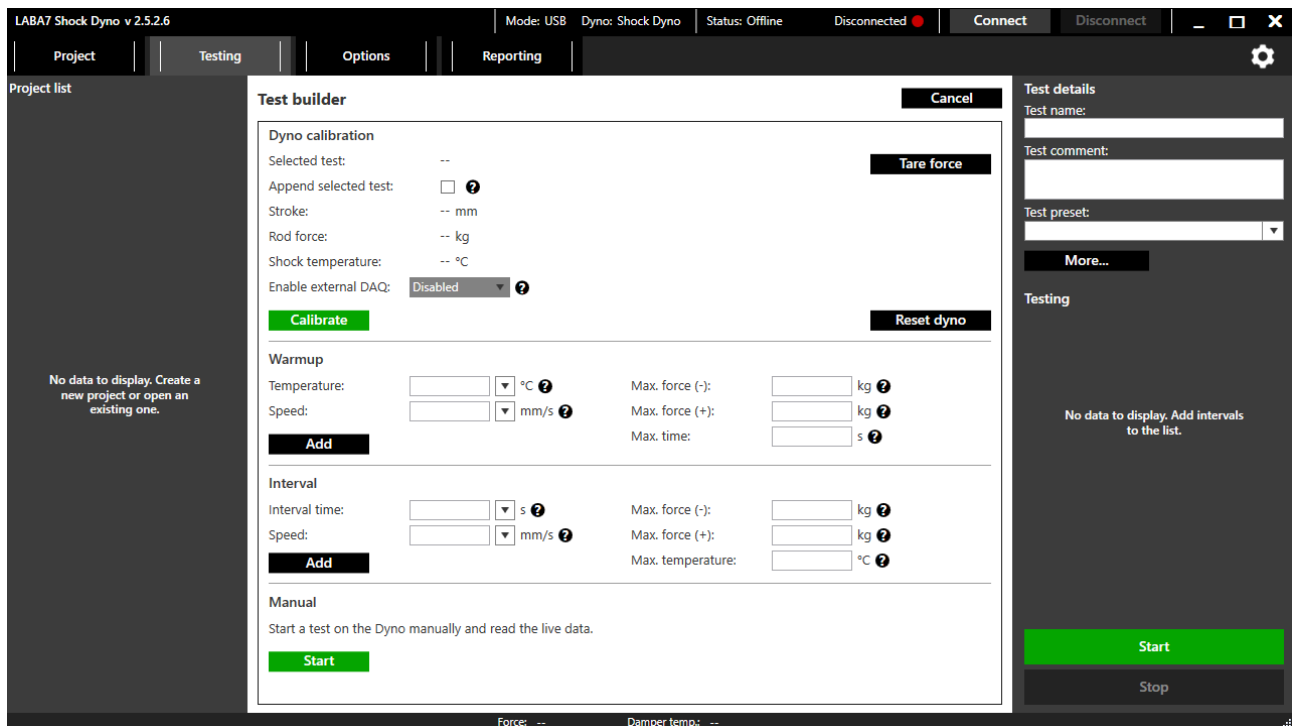

Figure 22

Make sure there is no interference for the dyno’s moving mast and press **Calibrate**.

During the calibration dyno measures parameters such as:

- Adjusted stroke
- Rod force
- Shock temperature

Additionally, you can click on the checkbox called “append selected test”, in this case, the stroke and rod force from the selected test will be used.

If the user engages emergency button, after disengaging it, the emergency state has to be reset by clicking **Reset dyno** button. After that, tests can be continued.

If the user wants to tare the load cell, he is allowed to press **Tare force**. This step is recommended to be done, while the dyno is empty.



**ATTENTION:** Make sure the temperature sensor that is located on the Dyno (see section 5.1 Overview) is pointing directly to the body of a shock absorber. For reflective surfaces such as chrome, apply a piece of electric tape.

## 11.4. Creating intervals

After project is created, dyno is calibrated – it is time to make a first test in our project.

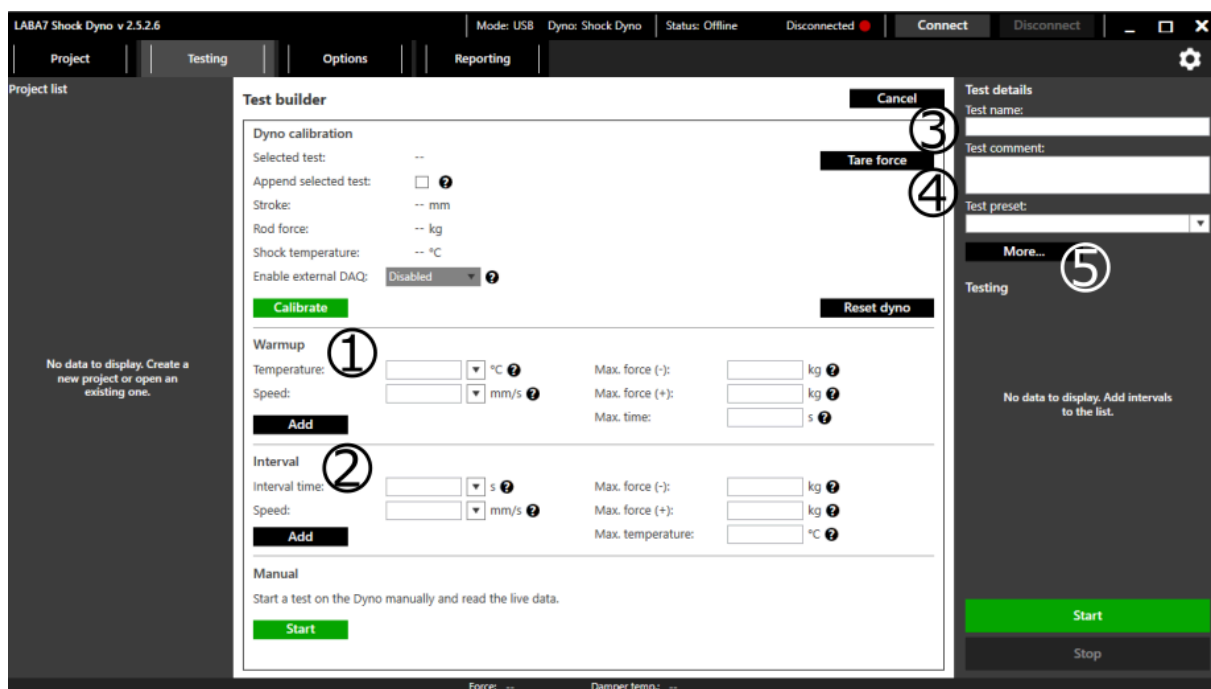

Figure 23

There are 2 interval types, which you can set in general settings:

- Cycle based intervals – intervals are based on cycles, 1 cycle is equal to 1 full rotation of the flywheel (compression and rebound).
- Time based intervals – intervals are based on time in seconds.

Testing includes 2 types of runs:

- Warmup – used to warm the damper to the working temperature (Figure 23 – Step 1).
- Interval – actual damper testing intervals, which will be used to test a damper (Figure 23 – Step 2).

To set up a warm up, the user has to do following steps:

1. Enter target temperature.
2. Enter the desired speed of the warmup.
3. Enter max rebound force (optional).
4. Enter max compression force (optional).
5. Enter max time (optional).
6. Press **Add**.

To set up intervals, the user has to do following steps:

1. Select from dropdown menu (or enter) the time (or cycle count).
2. Select from dropdown menu (or enter) the speed.
3. Enter max rebound force (optional).
4. Enter max compression force (optional).
5. Enter max temperature (optional).
6. Press **Add**.

To set up test summary information before test (optional), the user has to do the following steps:

1. Press **More...** (Figure 23 - step 5).
2. Provide additional test information before starting the test (for more information on test summary details, see paragraph 9.11).
3. Press **Set**.

After desired amount of intervals are added, to start the test, the user has to:

1. Enter test name (Figure 23 – step 3).
2. Enter test comment (Figure 23 – step 4).
3. Press **Start**.

After pressing start, all of the intervals will be executed in the same order as they were added.



**ATTENTION:** In order to create a successful test, Dyno needs to make 3 rotations to gather enough data to calculate all the graphs. If the time speed and stroke combination would result in a test that is not long enough to make 3 rotations, the software will display a warning and increase the required time automatically.

## Interval Presets

To make predefined interval presets, user has to locate “Options” button in the top of the screen, which is located next to “testing” button, then press “interval presets”.

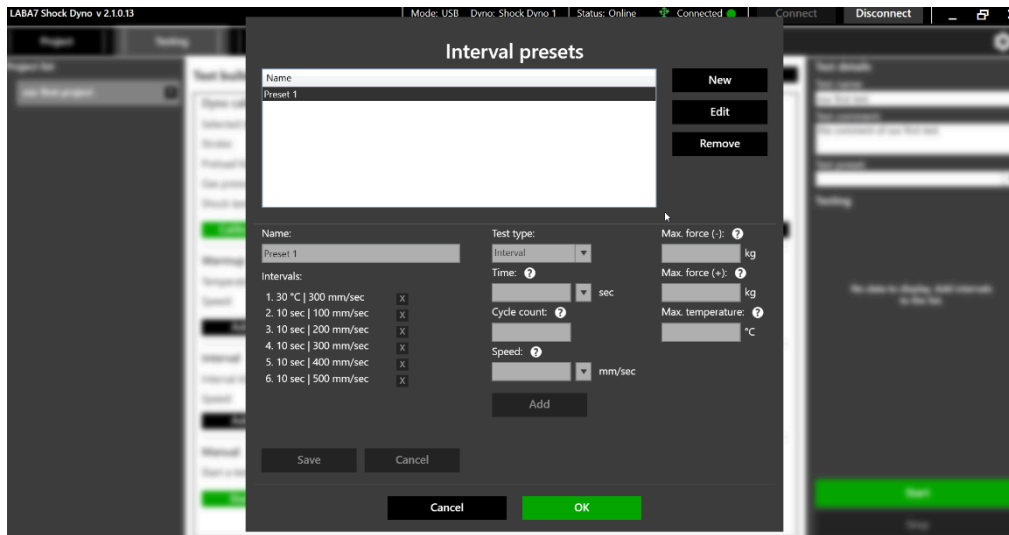

Figure 24

In order to add a new interval preset the user has to complete the following steps:

1. Press **New**.
2. Select the test type, either interval or warmup.
3. Enter time or cycle count.
4. Enter speed.
5. Enter max rebound force (optional).
6. Enter max compression force (optional).
7. Enter max temperature (optional).
8. Press **Add**.

After desired interval count is added, the user has to press **Save**.

## 11.5. Graph Comparison

In order to compare the graphs of recently done tests, the user has to exit the testing area by pressing **Cancel** button which is located in top right corner. Then, in projects list, which is located in the left side of the screen, press the dropdown arrow on the previously done test and select the runs you wish to compare.

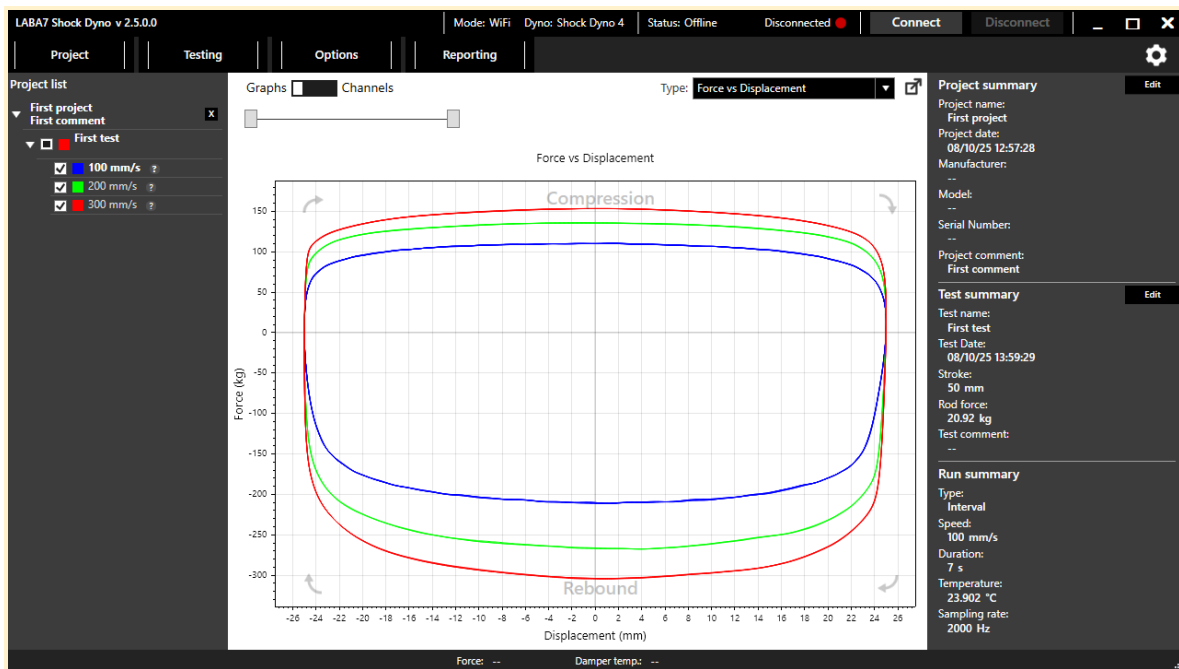

Figure 25

By clicking on the color of the checked test in the Recent Tests list, it is possible to change the color of the graph.

By hovering on a question mark icon with mouse in Recent Tests list, a tooltip will appear showing the parameters used for the test.

In order to add a visual data point in the graph view, use the left mouse button. There is no limit to the number of data points. Use the right mouse button to clear the data points.

By using the mouse scroll wheel, a user can zoom in or zoom out the displayed graphs.

Double-clicking the left mouse button on the graph area will restore the default zoom. It is possible to scroll only on one axis by using the scroll wheel directly over the horizontal or vertical axis label.

## 11.6. Graphs Data Mode Graph Types

The user has 2 options how to look at graphs: Graphs and Channels mode. This section describes the Graphs data mode. To switch between modes, the user has to locate switch button in the top left corner.

Graphs  Channels

### Force vs Displacement

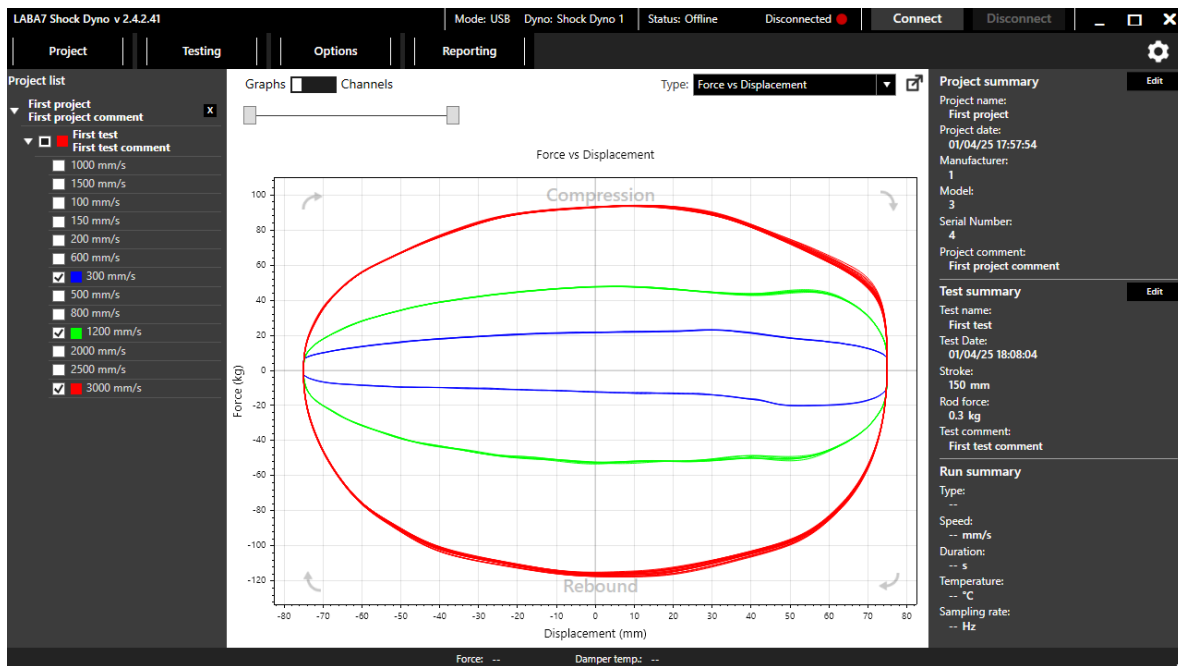

Figure 26

Force vs Displacement is a default graph presented upon launching the application. It is also used for the live test preview whenever a test is being performed.

The horizontal axis represents the displacement. 0 indicates the middle position of the stroke. The vertical axis represents the force. The positive force in the upper half of the graph represents the compression cycle, and the negative force in the bottom half of the graph represents the rebound cycle.

The left side of the compression and the right side of the rebound represent the speed-up, and the right side of compression and the left side of the rebound represents the slow-down of corresponding cycles.

## Avg. Force vs Displacement

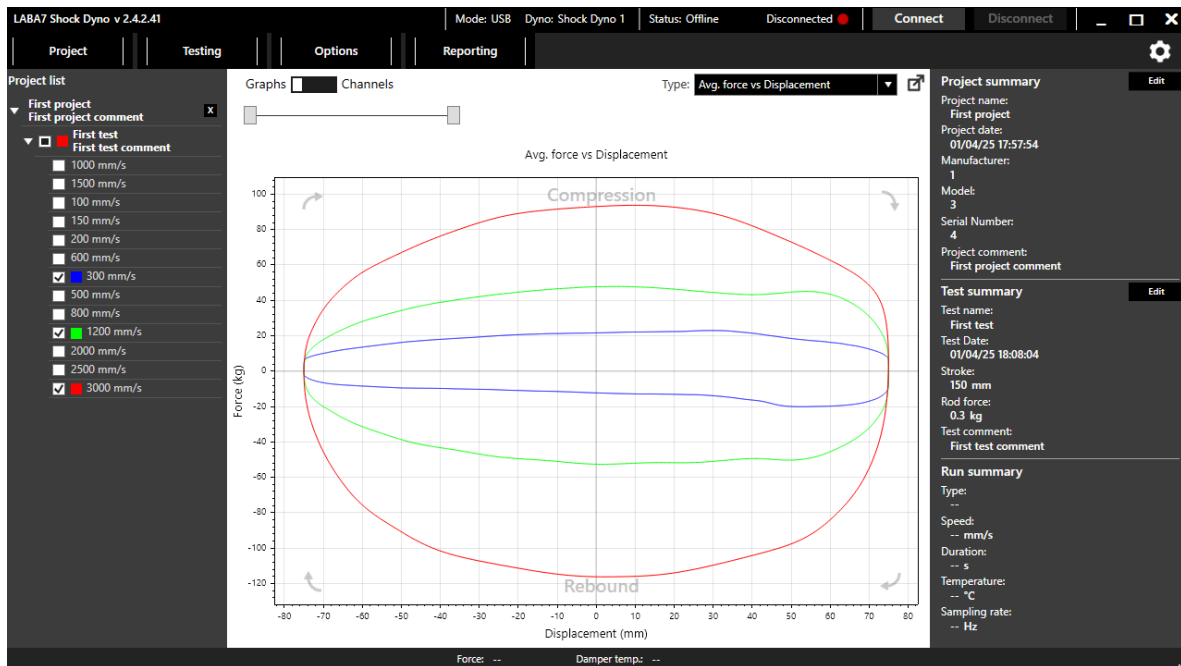

Figure 27

This graph is similar to Force vs Displacement graph; however, it averages the test into a single line, resulting in a graph without the hysteresis.

For details about the axes and compression/rebound cycles, see the section above.

## Force vs Velocity

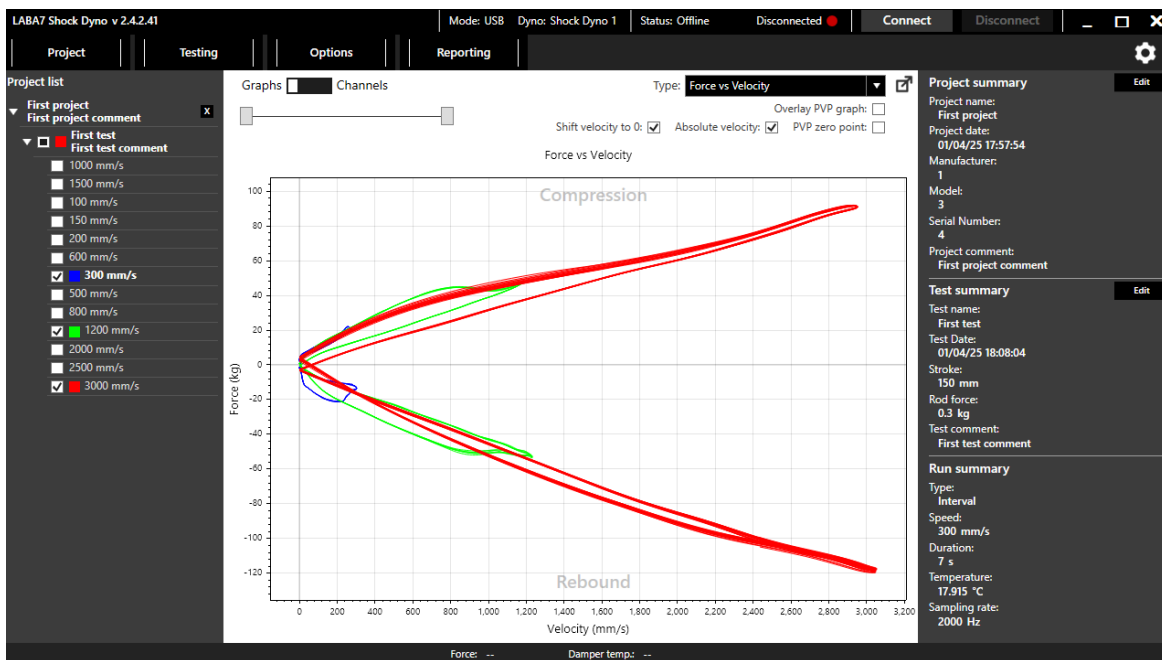

Figure 28

Force vs Velocity graph represents the change in force when the damper is compressed or released at a variable speed.

The horizontal axis indicates the linear speed of the damper, and the vertical axis indicates the resulting force.

The positive force at the top half of the graph represents the compression cycle and the negative force at the bottom half of the graph represents the rebound cycle.

## Force vs Avg. Velocity

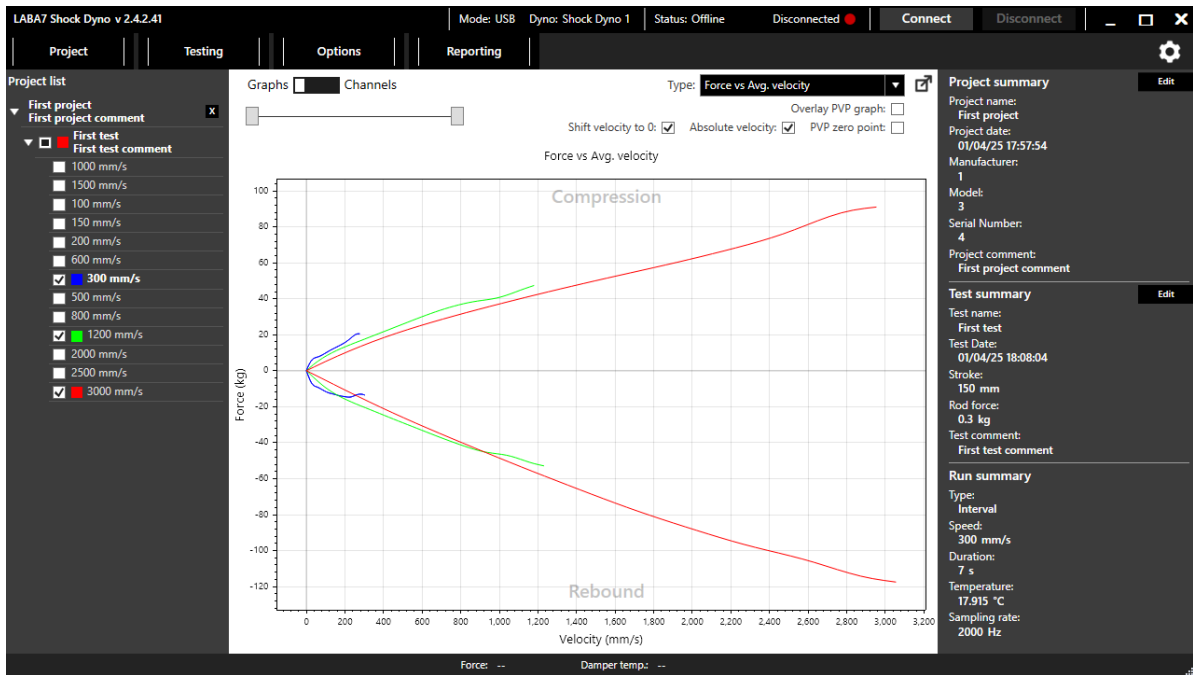

Figure 29

Force vs Avg. Velocity graph represents the average change in force for variable velocity. This graph is similar to Force vs Velocity; however, it shows the graph without the hysteresis. Furthermore, the speed-up and the slow-down of both compression and rebound cycles also averaged into a single line.

## Force vs Combined Velocity

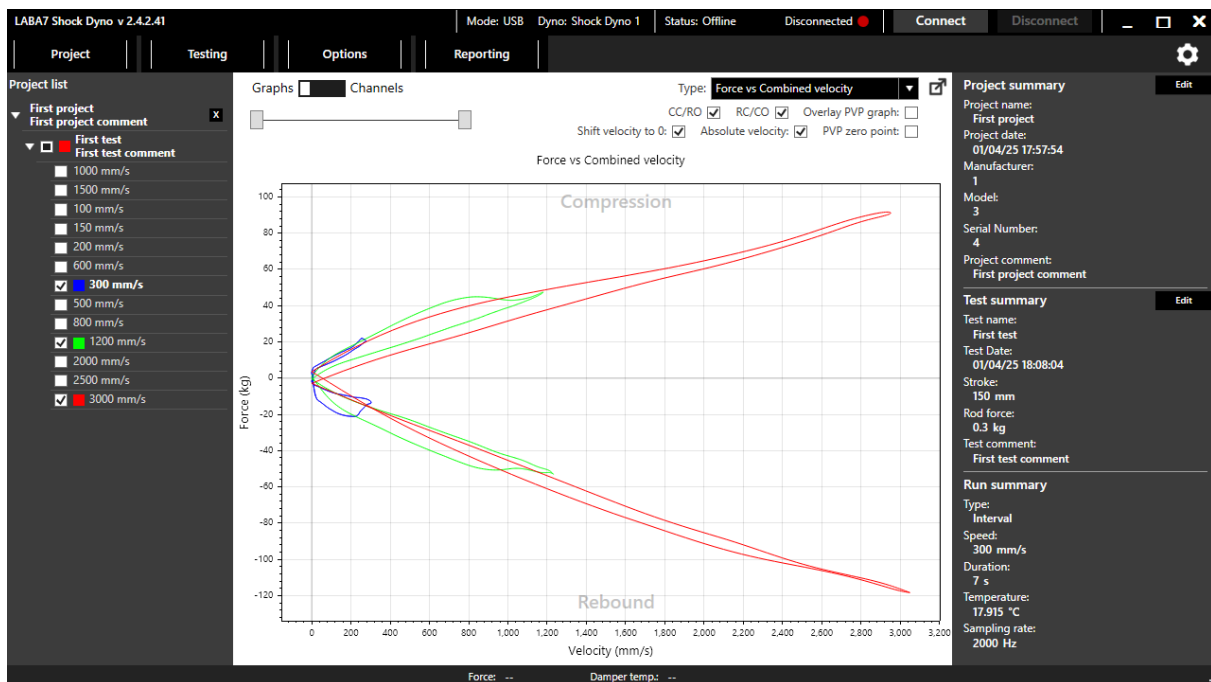

Figure 30

Force vs Combined Velocity graph represents the average change in force for variable velocity. This graph is similar to Force vs Velocity; however, it shows the graph without the hysteresis. The main difference between this graph and Force vs Avg. Velocity is that the speed-up and the slow-down of both compression and rebound cycles are shown as separate lines rather than being collided into a single one.

For details about the axes and compression/rebound cycles, see the section above.

## Force vs Peak Velocity

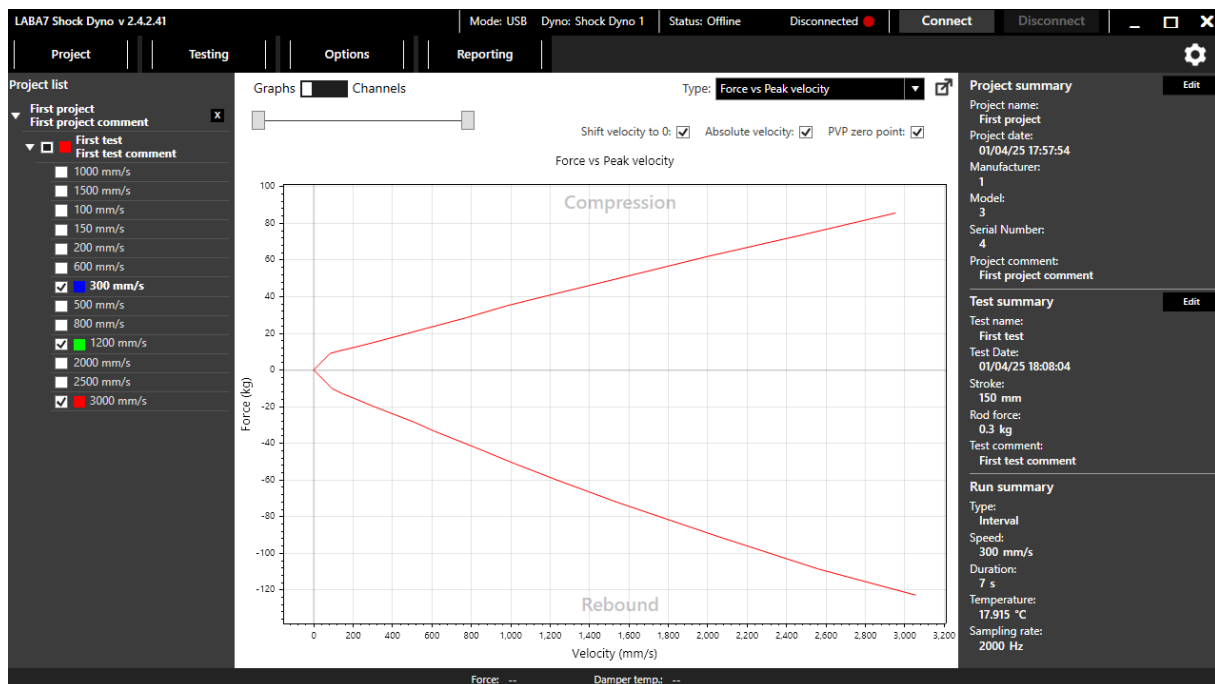

Figure 31

Force vs Peak Velocity graph is available for multiple speed tests.

The horizontal axis indicates the linear speed of the damper, and the vertical axis indicates the resulting force.

The graphs consist of a limited number of data points equal to the number of different speed intervals for both compression and rebound cycles. Each point represents a force at peak velocity for each interval.

## Force vs Time

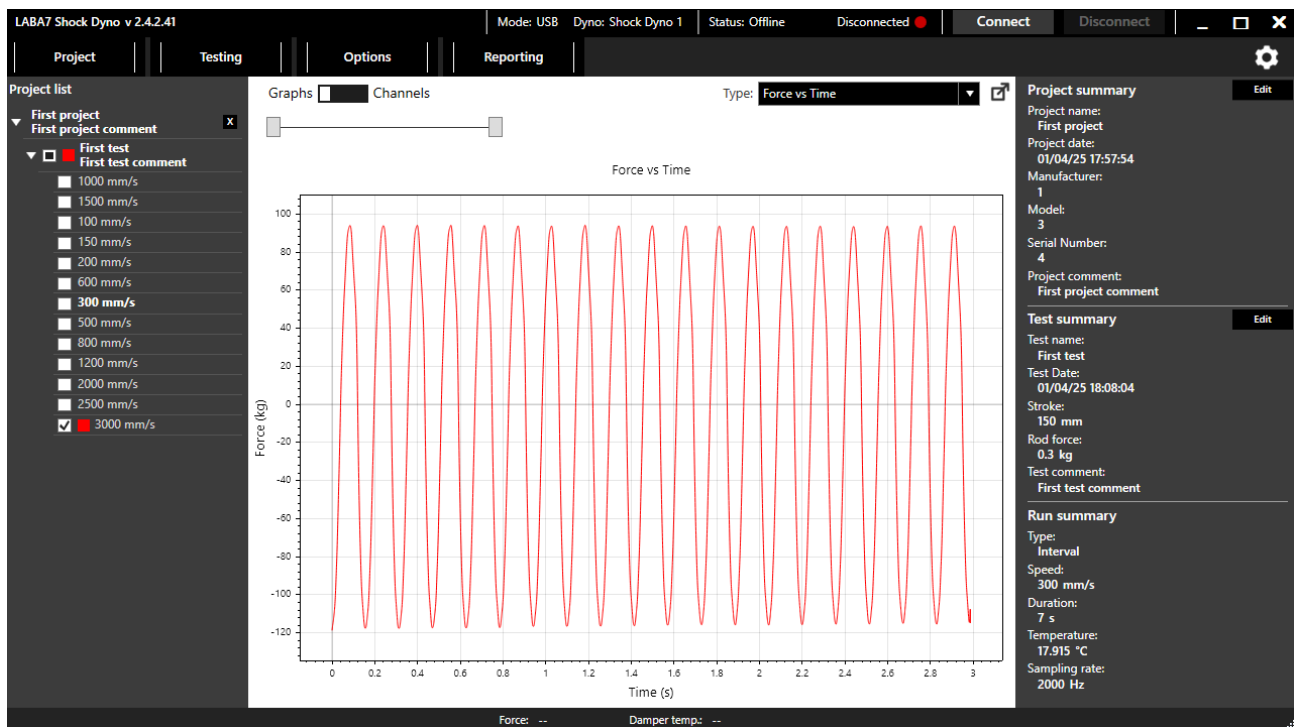

Figure 32

Force vs Time graph represents the force change in time.

The horizontal axis indicates the time, and the vertical axis indicates the change in force.

Such a graph can bring value to the user as it shows the change in the force for each different rotation of the Dyno throughout the whole test and can display details otherwise hidden in the Force vs Displacement graph.

## Temperature vs Time

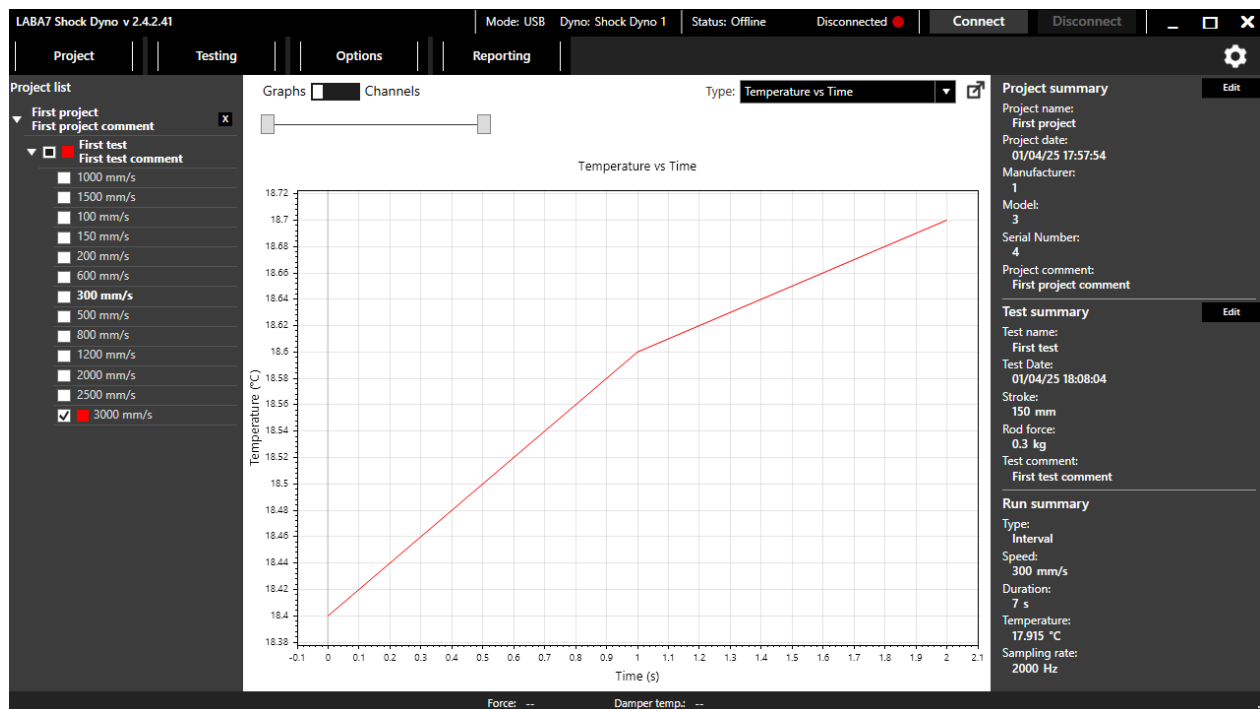

Figure 33

Time vs Temperature graph represents the warmup of the damper. It is not only available for the warmup test but also the interval runs.

The horizontal axis indicates the change in time, and the vertical axis indicates the temperature change.

## 11.7. Channels Data Mode Graph Types

In Channels data mode, user is allowed to look at 6 curves at once. The user can select from 6 types of curves:

- Force
- Displacement
- Velocity
- Current
- Temperature
- Acceleration

To view graphs user has to select them in the project list, on the left side of the software window.

By clicking on **Measure:**  checkbox in the top right corner, user can enable some measuring tools presented in the Figure 34 below.

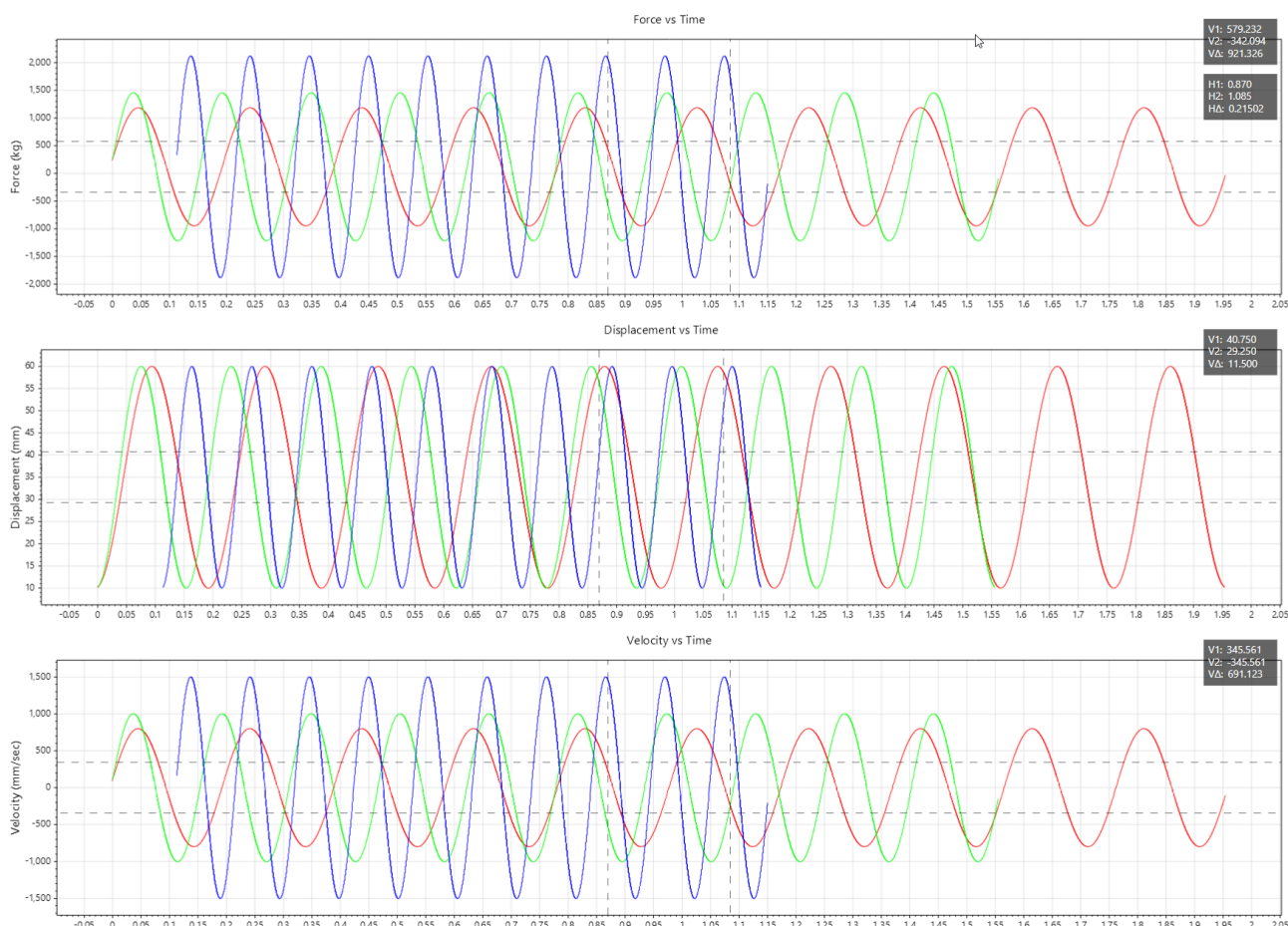

Figure 34

The user is also allowed to move the graphs in horizontal axis by clicking on **Move graphs:**  then, clicking on and dragging the desired graph. Comparison between original and moved graphs is showed in the Figure 35 below.

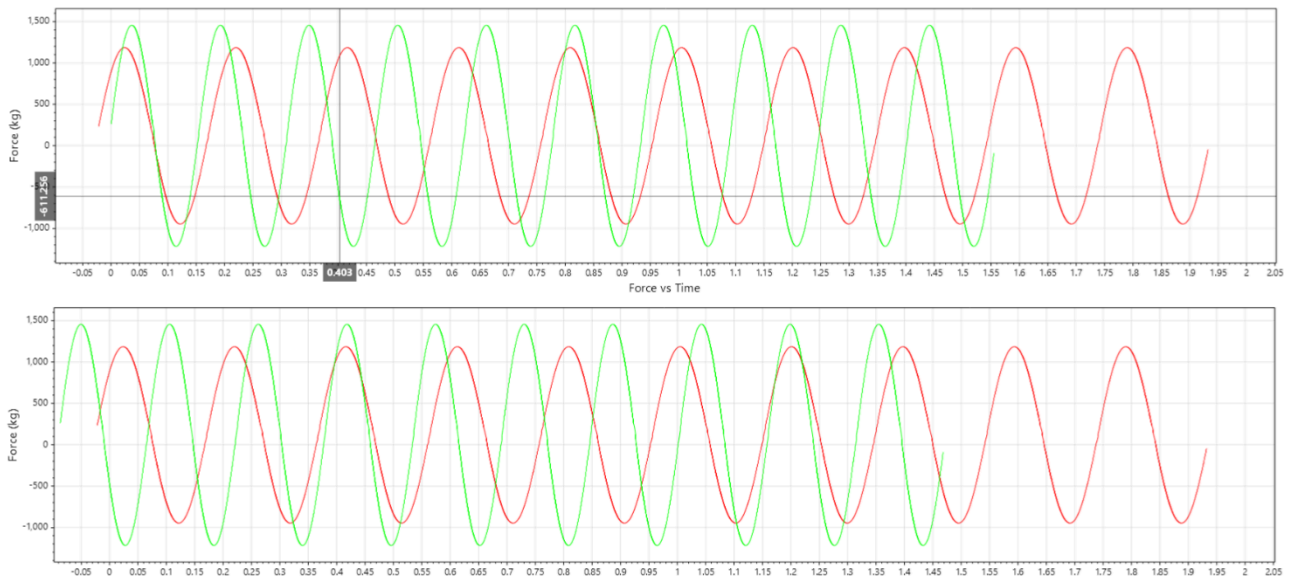

Figure 35

## 11.8. Graph Tools

Graph tools are enabled by checking the checkboxes. These tools are dynamic and only appear on velocity graphs. CC/RO and RC/CO appear only in “Force vs Combined velocity” graph type.

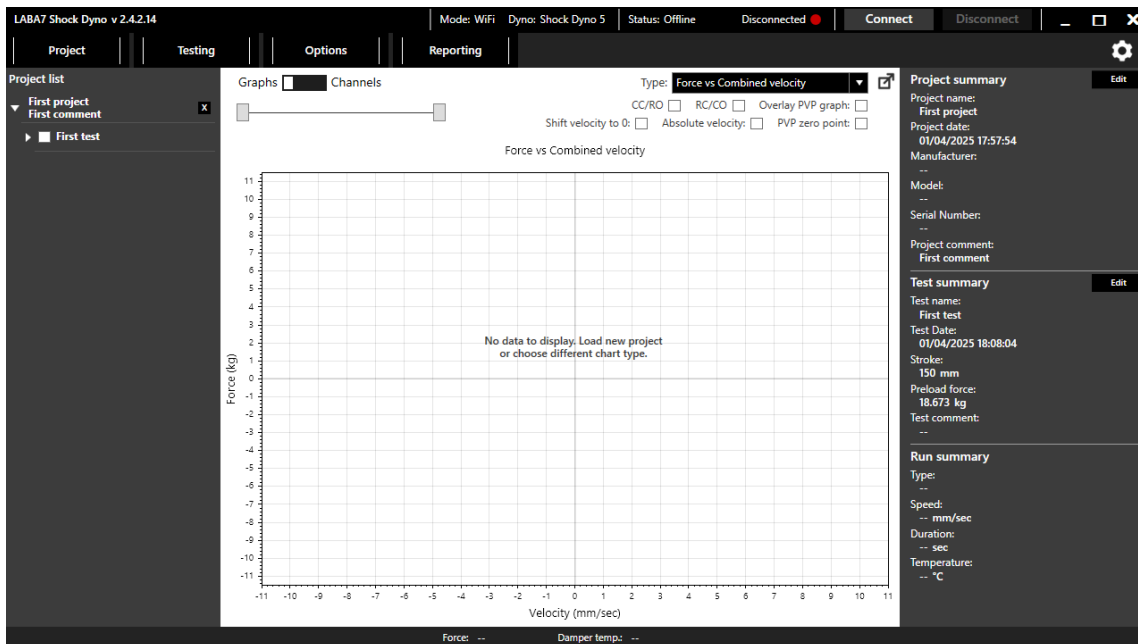

Figure 36

Shift velocity to 0 – shifts force axis to 0 or leaves it untouched when viewing a Force vs Avg. Velocity graph.

Absolute velocity – changes how velocity is presented in the graphs, either as a positive or negative speed for a rebound cycle.

PVP zero point – enables Peak Velocity graph interpolation, which fits the curve with new data points and smoothens the line.

Overlay PVP graph – displays the Peak Velocity Point (PVP) curve from the current test overlaid onto other selected runs/tests.

CC/RO – filters or emphasizes graph data with the compression circuit closed and rebound open, helping isolate rebound damping behavior.

RC/CO – filters or emphasizes graph data with rebound closed and compression open, highlighting compression damping performance.

## 11.9. Additional Test Options

In options menu, additional graph settings are available. To reach them, user has to press “options, then – hover over graph options and select his desired additional graph option.

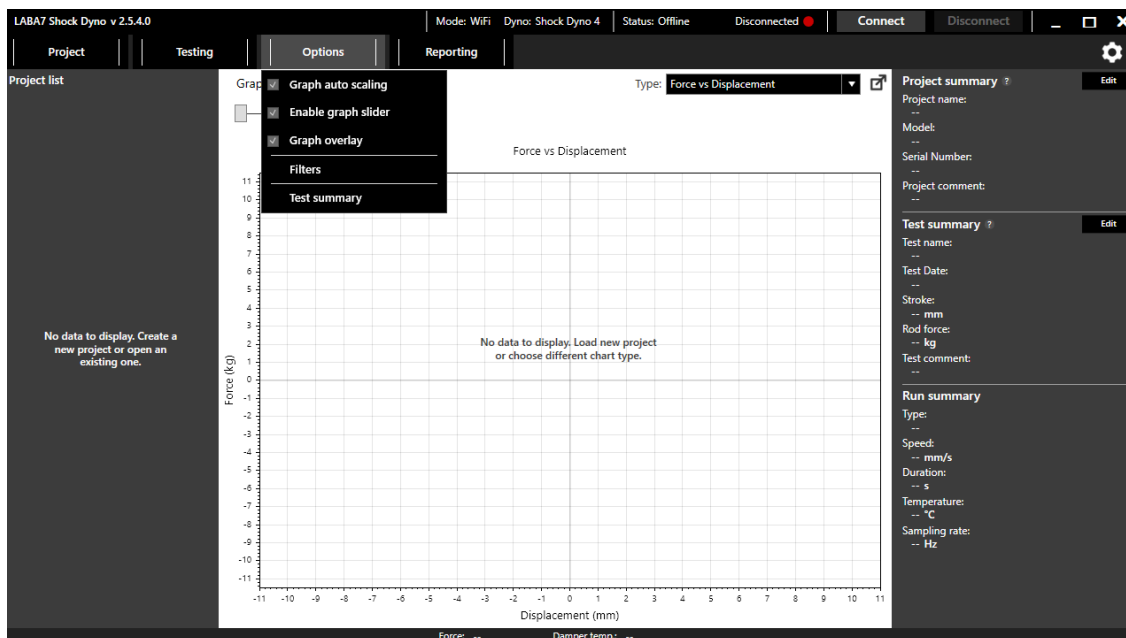

Figure 37

- Graph auto scaling – adjusts the zoom scale to best fit the active graph.
- Enable graph slider – enables the graph slider.
- Graph overlay – shows the cycle naming on the graph.
- Filters – opens the “Graph filter configuration” menu, where the user can select filter types, adjust filter settings, and enable or disable filters for individual graphs.
- Interval presets – opens “Interval presets” menu, where user can edit, and create new presets.
- Test summary – opens the “Test summary” window of the selected test.

### Graph Filter Configuration

The Graph Filter Configuration window allows the user to apply signal filters to individual graphs in order to smooth data or remove noise.

- Global Graph Filters – enables/disables all graph filters globally.
- Name – displays the name of the graph to which the filter can be applied.
- Filter – select the type of filter to apply to the selected graph.

- **None** – No filtering is applied.
- **Low Pass** – Removes high-frequency noise while preserving slower signal changes.
- **High Pass** – Removes low-frequency components and keeps rapid signal changes.
- **Moving Average** – Smooths the signal by averaging a number of neighboring data points.
- **Median** – Reduces noise spikes by replacing each point with the median value of surrounding points.
- **Filter Setting** – Defines the numeric parameter of the selected filter. The required input value depends on the filter type:
  - **Low Pass** – Enter the cutoff frequency in Hz.
  - **High Pass** – Enter the cutoff frequency in Hz.
  - **Moving Average** – Enter the window size (number of samples used for averaging).
  - **Median** – Enter the window size (number of samples used for median calculation).
- **Is Active** – checkbox to enable or disable the filter for that specific graph. If “Global graph filters” are **disabled**, this setting has no effect.

**Graph filter configuration**

Global graph filters: Enabled  ?

Channel Filters

Graph Filters

Name:	Filter:	Filter Setting:	Is Active:
Force vs Displacement	Low Pass	0	<input checked="" type="checkbox"/>
Avg. force vs Displacement	High Pass	0	<input type="checkbox"/>
Force vs Velocity	Moving Average	0	<input checked="" type="checkbox"/>
Force vs Avg. velocity	Median	0	<input type="checkbox"/>
Force vs Combined velocity	None	0	<input checked="" type="checkbox"/>
Force vs Time	None	0	<input type="checkbox"/>
Displacement vs Time	None	0	<input checked="" type="checkbox"/>

Figure 38

## 11.10. Open existing project

In order to open existing project, the user has to locate the “project” button in the top left corner and press “open existing”.

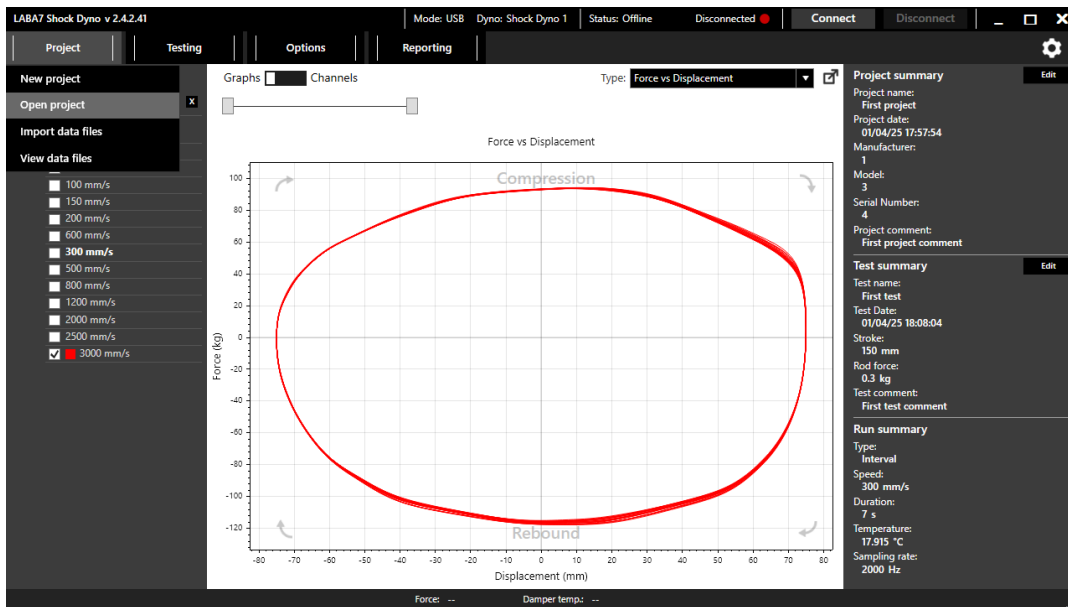

Figure 39

## 11.11. Test summary

In test summary edit window, user is allowed to eliminate spring force, also he is allowed to enter data about the device being tested.

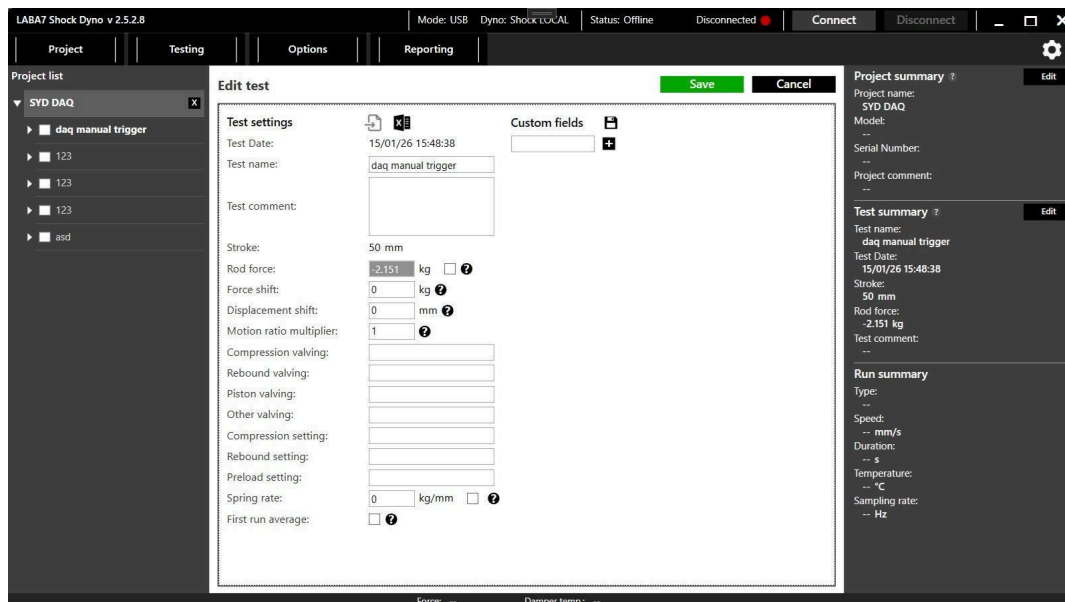



Figure 40

### Import/Export settings from/to Excel file

Allows user to Import/Export test summary information from/to Excel file and load it into another test by pressing .



### Import Test

Copies test summary from an existing selected test and inserts it into another test by pressing .

### Force Shift

The Force Shift function allows the user to apply a constant offset to the force signal. This adjustment affects plots and calculations while leaving the raw data unchanged.



To apply a force shift, follow these steps:

1. Locate the test summary window in the right screen of the screen.
2. Press .
3. Enter the desired force shift value (positive or negative).
4. Press .

### Displacement Shift



The Displacement Shift function allows the user to adjust the displacement reference of the shock dyno graph. This feature is useful when the measured displacement curve is offset or misaligned.

To apply a displacement shift, follow these steps:

5. Locate the test summary window in the right screen of the screen.
6. Press  .
7. Enter the desired displacement offset value (positive or negative).
8. Press  .



### Motion Ratio Multiplier

The Motion Ratio Multiplier function is used to convert shock (damper) movement into the corresponding wheel or tire movement. To apply the motion ratio multiplier, follow these steps:



1. Locate the test summary window in the right screen of the screen.
2. Press  .
3. Enter the motion ratio value.
4. Press  .

### Spring force elimination

To eliminate the force caused by a spring on the damper, the user has to know the spring rate value of the spring. To eliminate the spring force, follow these steps:

1. Locate the test summary window in the right screen of the screen.
2. Press  .
3. Enter the spring rate.
4. Click on the “eliminate spring rate” checkbox.
5. Press  .

### Custom fields

If the user needs to enter more data about the device being tested, he is allowed to make custom data fields. To make them, locate “custom fields” in top right corner of the test summary edit window. Type the needed parameter name and press  . If the user wants for those additional fields to be applied to all upcoming tests, user has to press  .

## First run average

This functionality calculates the average force of the first run in the test and eliminates this force for all upcoming runs. In order to do that, user has to pre **First run average:**  Eliminate 

Keep in mind, that the first run has to be the lowest speed in the whole test. Otherwise, the functionality will work improperly.

## 11.12. Settings

In the Settings menu, accessible through the main menu, a user can modify the settings related to the general use of the application and custom features related to the graph view.

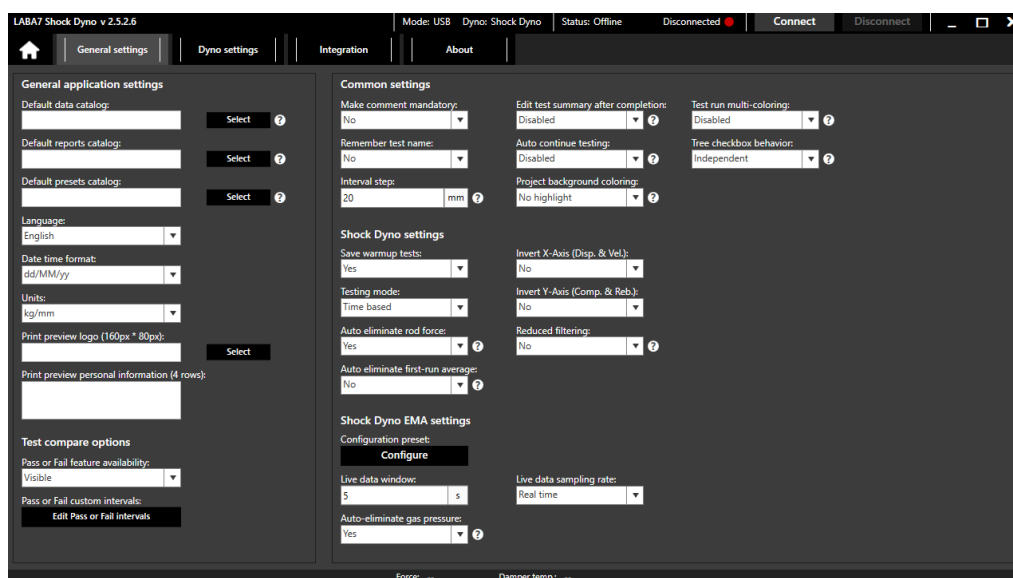

Figure 41

### General Settings

- Default Data Catalog – select the default location where the application will store tests. If the location is not selected then the software will store new tests in the same folder that was used most recently.
- Default reports catalog – select the default location where the application will store reports. If the location is not selected then the software will store new tests in the same folder that was used most recently.
- Default presets catalog – select the default location where the application will store presets. If the location is not selected then the software will store new tests in the same folder that was used most recently.
- Language – change to a different user interface language.
- Date time format – change how date and time is presented.

- Units – allows user to change different units of measurement.
- Print Preview Logo – choose an image file that will be visible on a print preview in the upper left corner.
- Print Preview Personal Information – enter any information that is going to be visible on a print preview in the upper right corner.

### Other Settings

- Make comment mandatory – makes the test comment mandatory.
- Remember test name – remembers test names that have been used before.
- Interval step – defines the step size for velocity intervals.
- Edit test summary after completion – opens the test summary window automatically after the test run is complete.
- Auto continue testing – opens the testing window automatically after the test run is complete.
- Project background coloring – determines how projects can be differentiated between themselves.
  - No highlight – same background for all projects.
  - Altering – odd and even projects will have different background color.
  - Colored – each project will have its own background color.
- Test run multi-coloring – when **Enabled**, each run under the selected test is assigned a different color. When **Disabled**, all runs use the same color.
- Tree checkbox behavior – determines how test and run checkboxes interact.
  - Default: The check state of a test and its runs is dependent. Checking a test automatically checks all its runs.
  - Independent: Each test and run can be checked or unchecked separately. Holding the Shift key while checking a test will also set the check state for its runs.
- Save warmup tests – makes the software save the warmup test in project.
- Testing mode – select the interval mode, cycle based or time based.
- Auto eliminate rod force – automatically eliminates rod force after the test run is complete.
- Auto eliminate first-run average – automatically eliminates first-run average after the test run is complete.
- Invert X-axis (Disp. & Vel.) – Inverts displacement and velocity X axis.
- Invert Y-axis (Comp. & Reb.) – inverts the compression and rebound Y axis.
- Reduced filtering – applies minimal digital smoothing to the load-cell signal, preserving high-frequency torque components while reducing sensor noise. Useful for observing natural motor behavior such as cogging torque or ripple.

## About

An area for registering the software, updating the software and checking release notes. Contact LABA7 support for a license key.

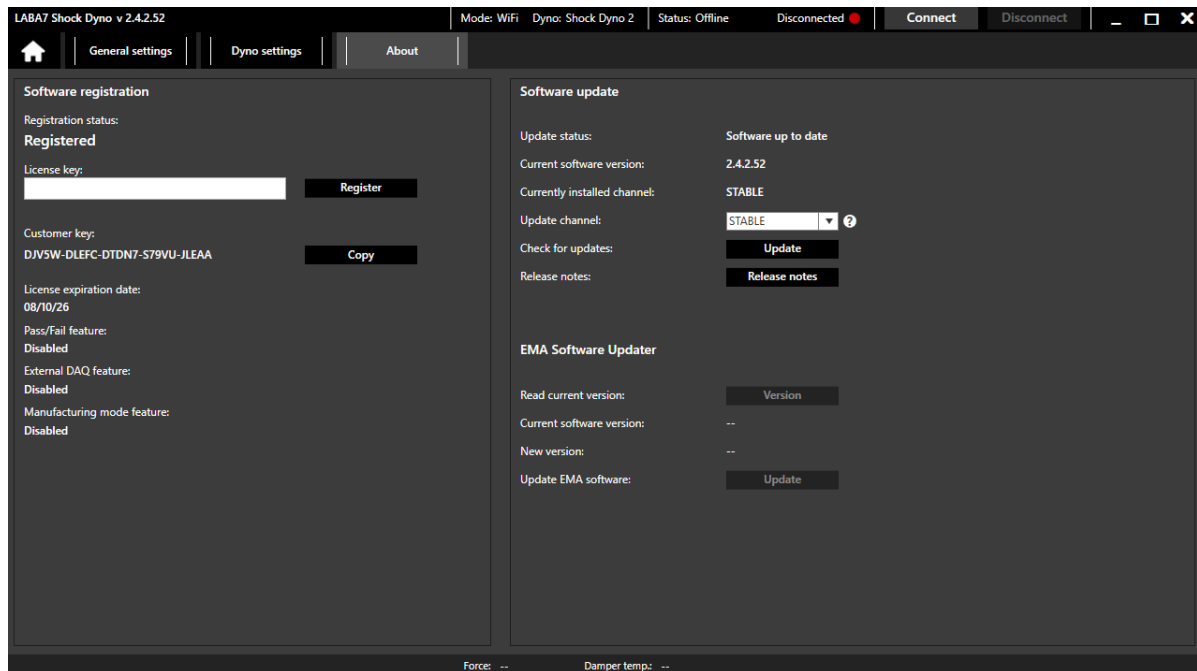

Figure 42

Update Channel function allows the user to choose which version stream of the software to receive updates from.

- STABLE – Provides thoroughly tested releases that prioritize reliability and long-term stability. Updates are less frequent but have undergone extensive validation.
- BETA – Provides access to the latest features, improvements, and fixes. However, these versions may be less stable or contain minor issues.

Changing the update channel takes effect only after performing a Check for Updates and installing the newly available version.

Release Notes provide a summary of the changes made in each new software version. They typically include information about newly added features, improvements, bug fixes, and any known issues.

## 11.13. Reporting

The application is capable of printing test reports to .pdf file. To access the functionality, press “reporting” button in the menu. There are 5 different report types, user can select between portrait and landscape print orientations as well.

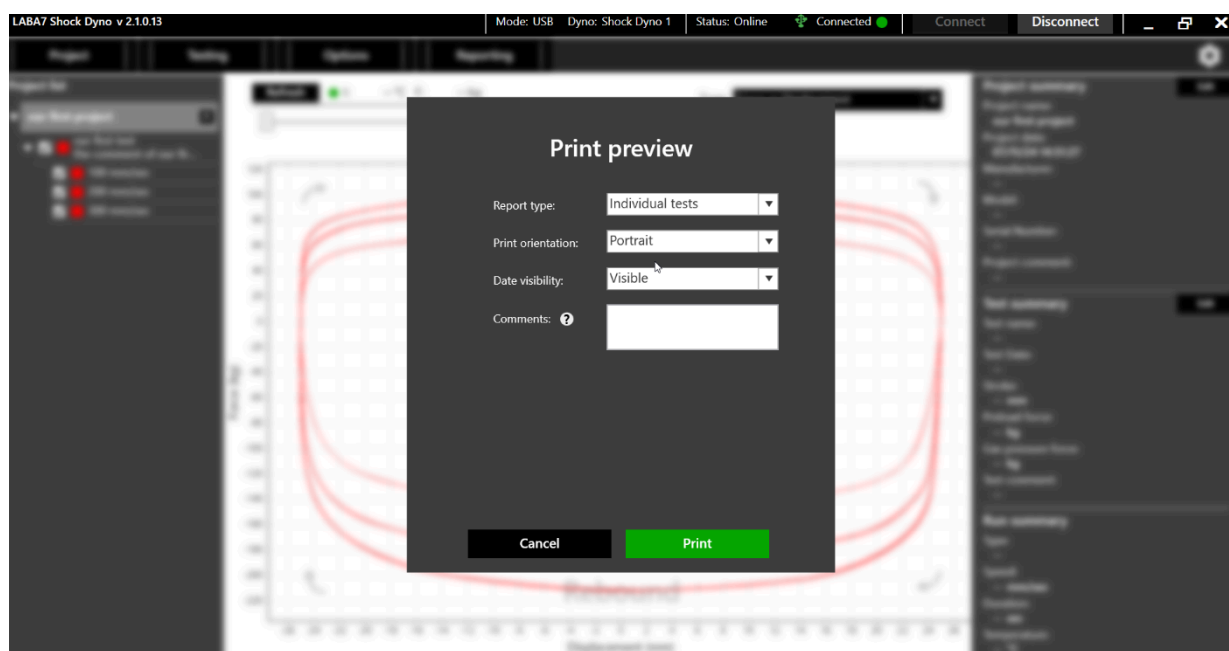



Figure 43

### Current graph report type

Current graph report type includes selected test runs and puts it into one page. To print current graph test report, follow these steps:

1. Select one or multiple test runs which you want to include into your report, from the project list.
2. Press “reporting”, then – “print”.
3. Select the “current graph” report type.
4. Select orientation.
5. Select date visibility.
6. Enter a comment if needed.
7. Press .

## Individual tests report type

Individual test report type includes selected test runs and puts it into separate pages. To print individual test report, follow these steps:

1. Select one or multiple test runs which you want to include into your report, from the project list.
2. Press “reporting”, then – “print”.
3. Select the “individual tests” report type.
4. Select the orientation.
5. Select date visibility.
6. Select speed table visibility.
7. Enter a comment if needed.
8. Press  .

## Comparison report type

Comparison report type includes all of the selected test runs in one graph, making it easy for the user to compare the runs. To print a comparison test report, follow these steps:

1. Select multiple test runs you wish to compare.
2. Press “reporting”, then – “print”.
3. Select comparison report type.
4. Select orientation.
5. Select legend visibility.
6. Select date visibility.
7. Select if separate by speed.
8. Enter a comment if needed.
9. Press  .

## PVP report type

PVP report type includes force vs displacement, force vs peak velocity graphs and peak velocity intervals table. To print PVP report, follow these steps:

1. Select multiple runs from the test.
2. Press “reporting”, then – “print”.
3. Select PVP report type.
4. Select orientation.
5. Select date visibility.
6. Enter a comment if needed.
7. Press  .

### **PVP comparison report type**

PVP comparison report type allows to compare 2 or more force vs peak velocity curves in one graph. To print PVP comparison report, follow these steps:

1. Select two or more tests by clicking on the test checkbox to select all of its runs.
2. Press “reporting” then – “print”.
3. Select PVP comparison report type.
4. Select orientation.
5. Select date visibility.
6. Select legend visibility.
7. Enter a comment if needed.
8. Press  .

## 11.14. Data Export and Import

The software is capable of exporting and importing test data from or to .csv file. There are two options of export: export interval and export PVP. To access this functionality, press “reporting” in the main menu.

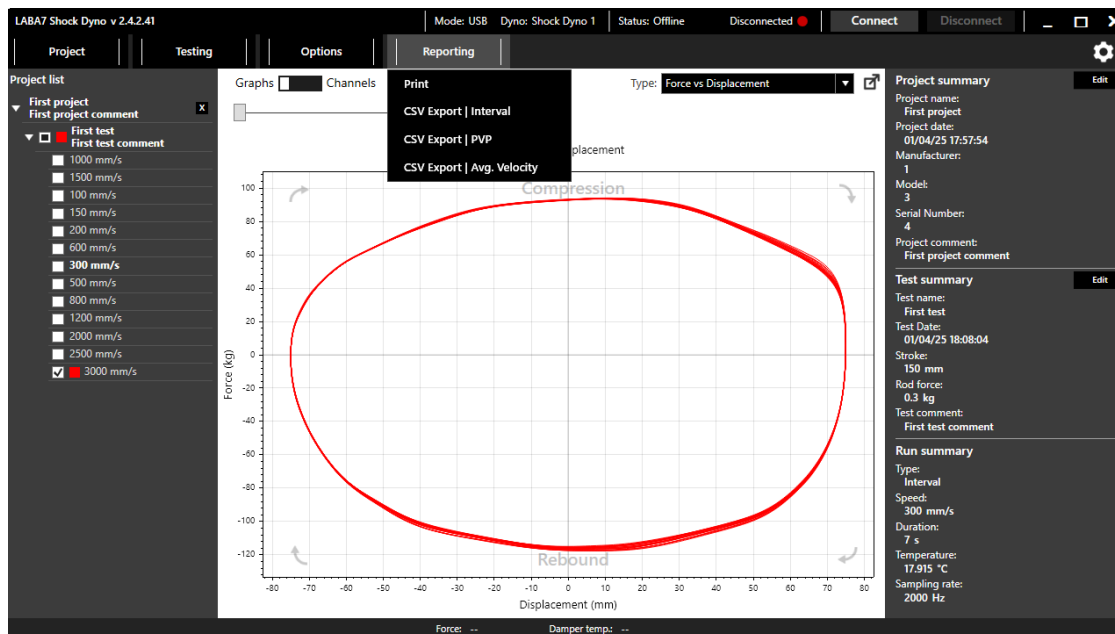

Figure 44

### Export interval

To export separate intervals, follow these steps:

1. Select one or more test runs from the project list.
2. Press reporting (figure 43).
3. Select **CSV Export | Interval**.

### Export PVP

To export peak velocity plot data, follow these steps:

1. Select multiple runs or whole test.
2. Press “reporting” (figure 43).
3. Select **CSV Export | PVP**.

### Export Avg. velocity

To export average velocity graph data, user has to follow these steps:

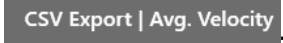
1. Select runs you want to export.
2. Press “reporting” (figure 43).
3. Select .

### Importing

The software allows user to import .csv files and old data files from older LABA7 versions of the shock dyno software.

To import old data files or .csv files, user has to follow these steps:

1. Press on “project” in the top left corner.
2. Click on .
3. Select the old data files the user wish to import.

Also the software allows user to view old data files, in that case, it is not possible to edit the imported file. To view old data files, user has to follow these steps:

1. Press on “project” in the top left corner.
2. Click on .
3. Select the files user wishes to view.

## 11.15. LABA7 manufacturing mode

The Manufacturing Mode feature can be activated by applying a valid license key. Once enabled, an additional Manufacturing option becomes available in the Settings menu. Within this section, the user can configure Operator Mode and/or Manufacturing Mode.

### Operator Mode

When Operator Mode is enabled, the user can define a password. This password will be required each time someone attempts to access the Settings menu, ensuring that only authorized personnel can modify system configurations.

### Manufacturing Mode

Enabling Manufacturing Mode provides access to additional configuration options that support production workflows. The following parameters can be defined:

- Manufacturing Barcode Path – specifies the file path used to store or retrieve barcode data required during the manufacturing process.
- Pass/Fail Preset File Path – defines the location of a preset file that determines acceptance criteria for product testing (e.g., thresholds, limits, and testing presets).
- Reports Path – sets the directory where test results and pass/fail reports are automatically saved for traceability.

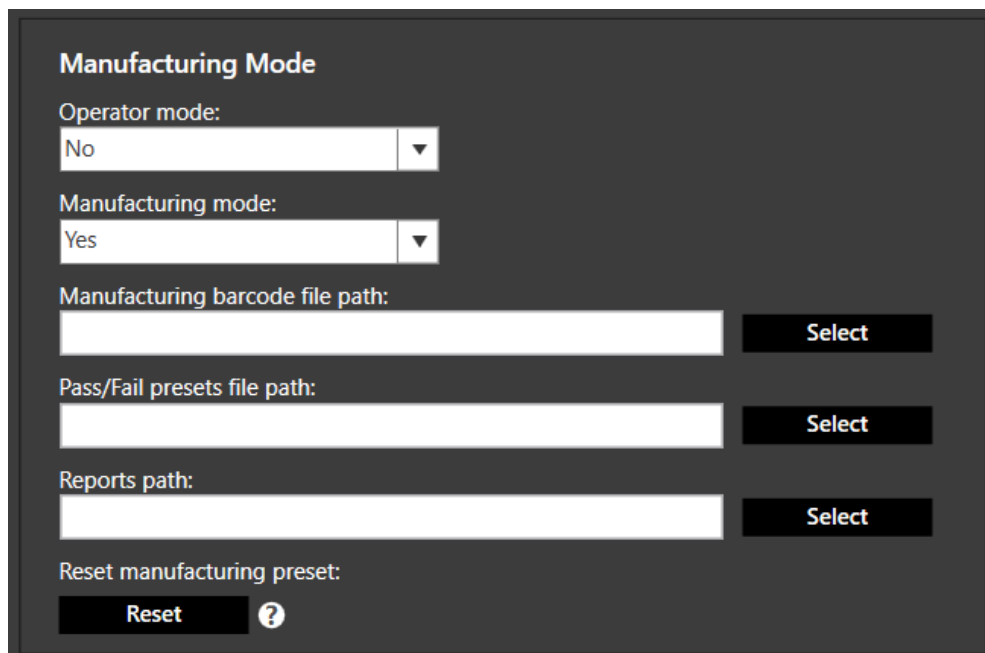

The screenshot shows a dark-themed configuration window titled "Manufacturing Mode". It contains several settings:

- Operator mode:** A dropdown menu currently set to "No".
- Manufacturing mode:** A dropdown menu currently set to "Yes".
- Manufacturing barcode file path:** A text input field with a "Select" button to its right.
- Pass/Fail presets file path:** A text input field with a "Select" button to its right.
- Reports path:** A text input field with a "Select" button to its right.
- Reset manufacturing preset:** A "Reset" button with a question mark icon next to it.

Figure 45

### Pass/Fail Preset File

The Pass/Fail Preset File defines the acceptance criteria used to evaluate test results. It contains a list of schema names, each of which specifies tolerance values and force limits for both compression and rebound tests.

### Tolerance and Force Values

Each row represents one schema. The file includes a tolerance percentage and the corresponding target force values.

Example: If the tolerance is 10% and the compression target is 30 kg, the acceptable range will be 27 kg to 33 kg.

Both compression and rebound parameters can be defined within the same schema.

### Test Speed and Interval Definitions

Columns D–F and H–J (Row 3): define different test speeds (in mm/sec).

Columns D–F and H–J (Row 4): define the corresponding time intervals for each test.

These parameters are used to create an automatic testing preset once a barcode schema is matched.

### Barcode Integration

A single barcode may reference multiple schema codes (e.g., one for compression, another for rebound). When a barcode is scanned and its schema code is identified, the software automatically applies the correct preset for the test.

This structure ensures that each unit is tested against the correct performance limits, reducing the risk of operator error and ensuring consistent product quality.

	A	B	C	D	E	F	G	H	I	J
1		scheme								
2				COMP				REB		
3				50	150	200		50	150	200
4		± % requested		8	4	2		8	4	2
5	15%	S1		33.4	66	83.7		-20	-55	-74
6	10%	CD1		37	58	97		0	0	0
7	10%	CD2		46	65	100		0	0	0
8	10%	CD3		30.14	43.95	94.49		0	0	0
9	10%	CD10		34.14	43.09	72.33		0	0	0
10	10%	CD11		50	80	100		0	0	0
11	10%	CD12		100	120	150		0	0	0
12	10%	CD13		120	140	170		0	0	0
13	10%	CD14		130	150	180		0	0	0
14	10%	CD15		140	160	190		0	0	0
15	10%	CD22		5.4	6.5	9.5		0	0	0
16	10%	CD17		160	180	219		0	0	0
17	10%	CD18		170	190	229		0	0	0

Figure 46

### Manufacturing Barcode File

The Manufacturing Barcode File contains barcode records used by the software during barcode scanning. When a user scans a barcode, the software searches this file (Excel format) for a matching entry.

Each row in the file corresponds to a single barcode and typically includes the following information:

- Serial Number – the unique identifier of the manufactured unit.
- Order Number – the production or work order associated with the unit.
- Operator – the name or ID of the operator responsible for handling the unit.
- Validation Schema Codes 1 and 2 – the most critical fields, which specify which pass/fail validation schemas must be applied.

The Validation Schema Code links directly to a schema defined in the Pass/Fail Preset File. These presets contain acceptance limits and rules against which the test results are validated. By combining the Manufacturing Barcode File with the Pass/Fail Preset File, the software ensures that each unit is tested according to its designated quality requirements.

	A	B	C	D	E	F	G	H	I	J
1	<b>Barcode</b>	<b>Serial number</b>	<b>ODP nr</b>	<b>Q.ty</b>	<b>Operator</b>	<b>Codice prova</b>	<b>Scheme 1</b>	<b>Scheme 2</b>	<b>GAS press.</b>	<b>GAS press.</b>
2				<b>for ODP</b>			<b>compression</b>	<b>rebound</b>	<b>Bar min</b>	<b>Bar max</b>
3										
4										
5	123	S424/003769954Q2	24/02354	1	Andrius	Road	CD10	RD5	4.3	5.8
6	234	S424/003769954Q2	24/02354	1	Andrius	Road	CD10	RD5	4.3	5.8
7	abc	S424/003769954Q2	24/02354	1	Andrius	Road	S1	S1	4.3	5.8
8	BW0038XXZ31V2	S424/003769954Q2	24/02354	1	Andrius	Road	CD10	RD5	4.3	5.8
9	BW0038XXZ31V2	S424/003769954Q2	24/02354	1	Andrius	Road	CD10	RD5	4.3	5.8
10										

Figure 47

**Reports File**

The Reports File is automatically generated and updated by the software after each completed test sequence. It serves as a record of both product details and test outcomes, ensuring full traceability of the manufacturing process.

Each report entry typically includes the following information:

- Serial Number – the unique identifier of the tested unit.
- Barcode – the scanned barcode associated with the unit.
- Operator – the name or ID of the operator who performed the test.
- Schema Names – the compression and/or rebound schemas applied, as defined in the Pass/Fail Preset File.
- Additional Barcode Data – other parameters referenced from the Manufacturing Barcode File.
- Test Results – detailed results for each individual test conducted during the sequence.
- Final Result – the overall pass/fail outcome based on the preset acceptance criteria.
- Date and Time – timestamp of the test sequence.

**File Handling Rules**

Reports are automatically saved by the system; no manual intervention is required. A new report file is created for each calendar day.

All results from the same day are appended to the corresponding daily file.

This structure ensures that production records are consolidated, easy to track, and suitable for both quality assurance and auditing purposes.

	A	B	C	D	E	F	G	H	I	J	K	L	M	N
1	ODP	Barcode	Serial	Run 1	Run 2	Run 3	Q.ty	Stroke mm	Operator	Scheme 1	Scheme 2	Date	Time	Pass/Fail
2	25/05359	T525/003E	SC232YGB	Fail	Fail	Fail	1	25	Andrius	96-15		2/9/2025	11:07	Fail
3	25/05359	T525/003E	SC232YGB	Fail	Fail	Fail	1	25	Andrius	96-15		2/9/2025	11:49	Fail
4														

Figure 48

### Manufacturing Workflow

When Manufacturing Mode is enabled, selecting “Testing” in the software opens a dedicated workflow window. This window provides several key functions to prepare and execute tests:

#### Preparation

- Tare Force – resets the force measurement to zero before testing. Should be used when the dyno is empty and no damper is inserted.
- Dyno Calibration – calibrates the dyno, which measures the damper preload force.
- Real-Time Test – allows the operator to verify that the damper is inserted correctly and that the preload is applied as expected.

#### Barcode Input

A Barcode Textbox is provided for entering or scanning a barcode (via barcode scanner). Once entered, the software:

- Reads the Manufacturing Barcode File.
- Searches for the matching barcode entry.
- Retrieves the associated schema codes.
- Matches these codes with the corresponding schemas in the Pass/Fail Preset File.

Based on this process, the software automatically generates a testing sequence along with the required acceptance criteria for pass/fail validation.

#### Test Execution and Reporting

The defined test sequence is executed automatically.

After completion, a new entry is appended to the Reports File, recording both product information and test results.

#### Pass/Fail Window

In Manufacturing Mode, a Pass/Fail window is always displayed to the operator.

This window provides immediate feedback on whether the test sequence passed or failed.

The displayed results are updated automatically when different tests are selected from the Projects List.

This workflow ensures that all tests are performed consistently, validated against the correct criteria, and fully documented for traceability.

### Test builder

**Dyno calibration**

Selected test: -- Tare force

Stroke: -- mm

Rod force: -- kg

Shock temperature: -- °C

Enable external DAQ: Disabled ?

Calibrate Real time Reset dyno

---

**Manufacturing Mode** Scan

Scanned barcode: abc

Selected test preset: Manufacturing

Selected Pass/Fail preset: CD10 RD5

Cancel

### Test details

Barcode: abc

Test comment:

---

### Testing

1. 8 s   55 mm/s	X
2. 4 s   165 mm/s	X
3. 2 s   220 mm/s	X

Start

Stop

Figure 49

## 12. DAQ configuration

To access the DAQ configuration menu, navigate to “Settings” and go to the “Integration” tab. In the “Custom sensors enabled” field, select “Enabled” from the drop-down menu. If the connected DAQ device is not visible, click “Refresh” to rescan for available devices. After accessing the DAQ configuration menu, users can use functions and configure the parameters described below.

NOTE: This function is available only with an activated license key. To obtain a license key, please contact support.

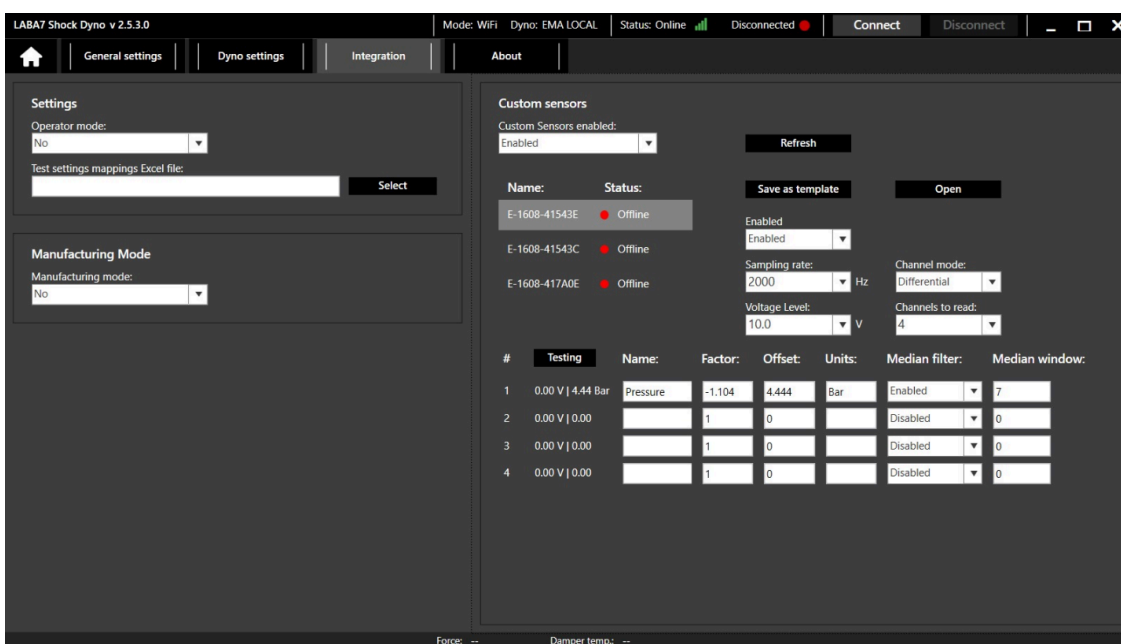

Figure 50

- Name — specifies the name of the DAQ device. This name is used to identify the DAQ within the system.
- Status — indicates whether the DAQ device is currently connected. The status can be Online or Offline.
- Save as template — saves the current DAQ configuration parameters as a template that can be reused.
- Open — opens a previously saved template and applies its configuration parameters.
- Enabled — enables the current device so the data can be collected during testing.
- Sampling rate — sets the rate at which the DAQ collects data.
- Voltage level — sets input voltage level.
- Channel mode — selects the measurement mode for each DAQ channel. Two modes are available:

- Differential — measures the voltage difference between two input terminals. This mode helps reduce noise from external interference and is useful for precise measurements.
- Single-ended — measures the voltage between the input terminal and the DAQ's ground. This mode is simpler but more susceptible to noise.
- Channels to read — allows you to select which DAQ channels will be active for measurement.
- Name — specifies the name of the sensor connected to the DAQ.
- Factor — multiplies the measured value by a specified number to convert it into the desired units.
- Offset — adjusts the measured value by adding or subtracting a fixed amount.
- Units — specifies the measurement units for the sensor's data.
- Median filter — applies a median filter to the sensor data to reduce noise.
- Median window — defines the number of data points used by the median filter. Larger values increase smoothing but may reduce responsiveness to rapid changes (default value for Median window: 7).

When configuring a channel, all the information must be filled. If any of the fields like Name or Units is empty, channel will not be recorded. Median filter for each channel is applied individually and during data collection. Data channels are labeled 1 to 8 from left to right on the device (1 to 4 for differential mode). If the user connects a sensor to 3rd channel, all 3 channels in the software will have to be configured.

If single-ended mode is selected, the following channels correspond to labels on the device:

- Channel 1 — CH1+
- Channel 2 — CH1-
- Channel 3 — CH2+
- Channel 4 — CH2-
- Channel 5 — CH3+
- Channel 6 — CH3-
- Channel 7 — CH4+
- Channel 8 — CH4-

If differential mode is selected, the channel labels match the channel numbers:

- Channel 1 — CH1+ and CH1-
- Channel 2 — CH2+ and CH2-
- Channel 3 — CH3+ and CH3-
- Channel 4 — CH4+ and CH4-

POWER OUTPUT (500 mA MAX EACH)

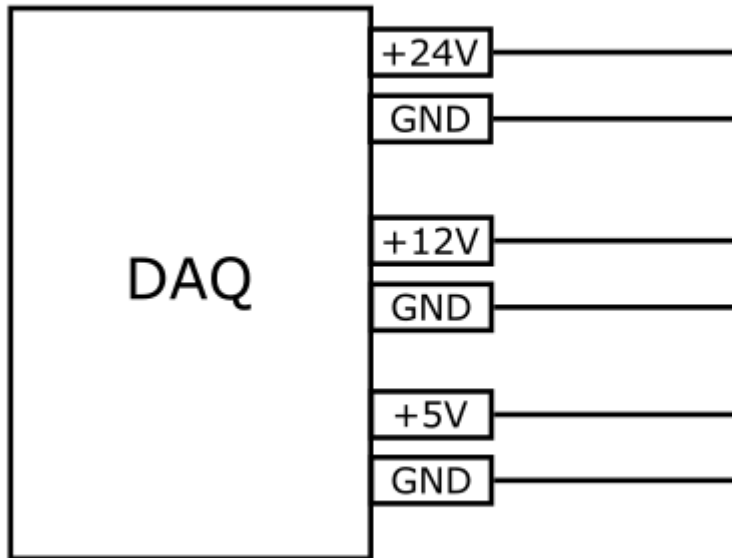

Differential Analog Input

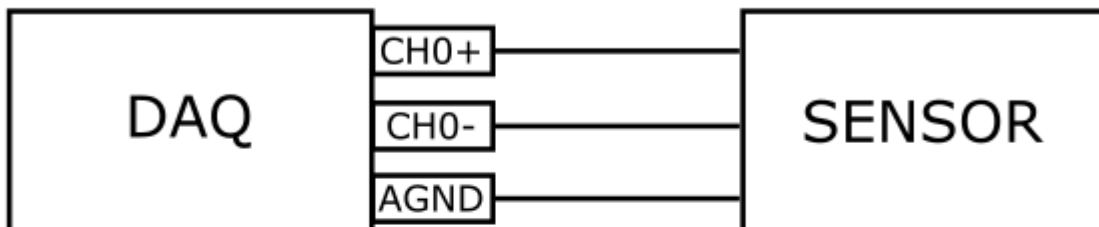

Single-Ended Analog Input

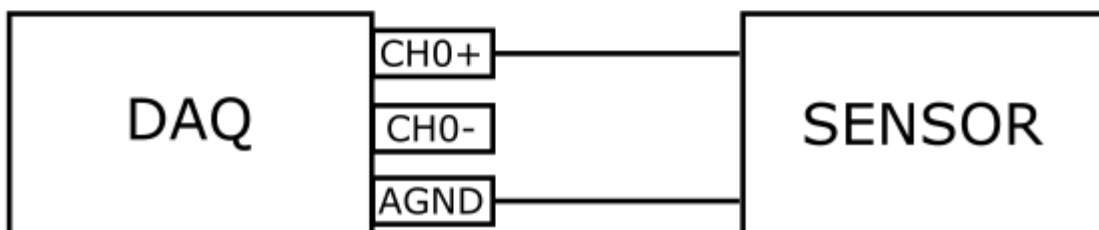

Figure 51

### 13. Electrical wiring

The LABA7 3 phase shock dynos are wired for TNS 3 phase wiring systems. Check the image bellow to determine which wiring your building has. If the user has different power system in his workshop, he has to reach the LABA7 customer support for instructions.

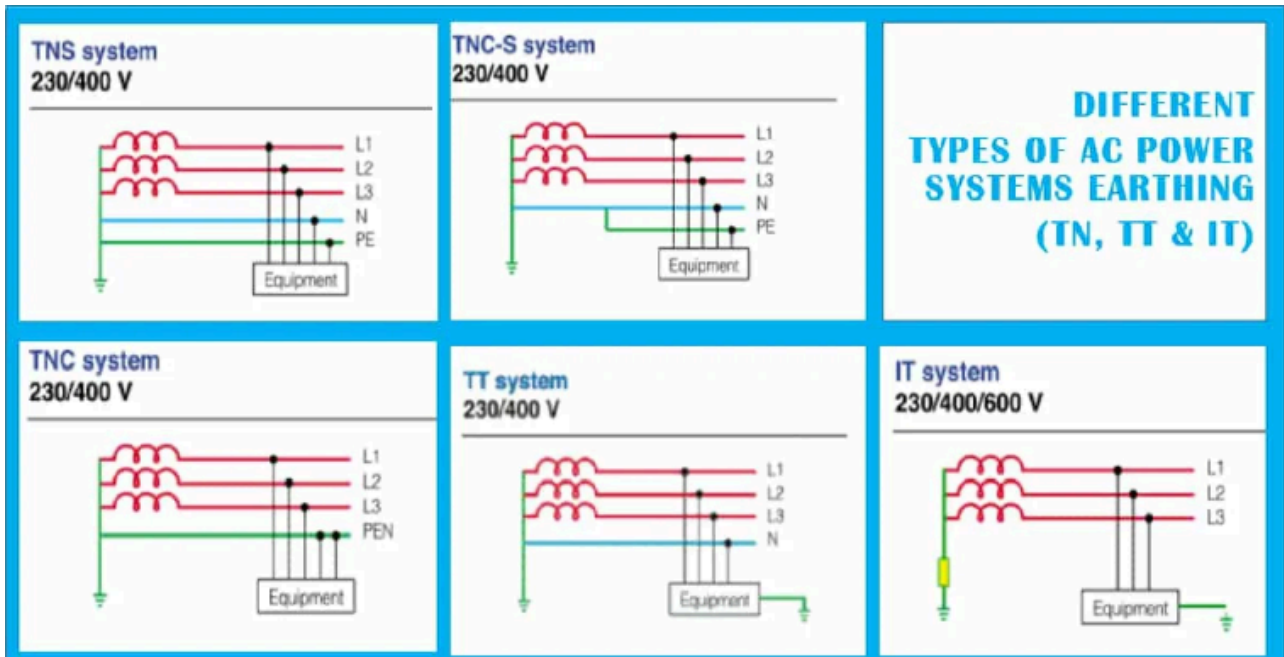

Figure 52

## 14. Troubleshooting

This section defines the most common issues that can arise when using the Dyno related to communications, data transfer, application, or mechanical issues and what steps to take in order to fix them.

### 14.1. General

Issue	Solution
Dyno is not responding, unable to communicate.	Both, Dyno and the application, might be stuck on a loop, or a cache of either one can be full. Restart the Dyno (powering it off and unplugging the USB cable for 1 minute) and restart the application on a computer.
Application is frozen or stuck on a Please Wait dialog and cannot be closed.	Close the application through the Task Manager. If application is stuck on a USB connection, unplug the USB cable to properly shut down the application.
Dyno stops during the test, and when running another test, dyno is not running, only noise is seen on the graph.	During the previous test motor has reached overload, restart the machine.
Cannot communicate with Dyno over USB, Com Port does not appear in the selection.	Reconnect the USB cable (check the sockets on both ends – computer and Dyno). If the issue persists, try a different USB cable, as the latter might be damaged.

### 14.2. Wi-Fi Configuration

Issue	Solution
Cannot configure Wi-Fi parameters.	The communication mode in Dyno is incorrect. Change the communication mode.
Cannot change communication mode.	The com port number might be incorrect. Select the proper com port number and try again.
Cannot connect to router.	The router might not allow new connections; check the router settings or restart it.

	Check for typos, if caps lock is enabled, re-enter credentials.
Dyno is connected but status appears to be offline.	The computer is not connected to the same network as the Dyno. Reconnect device to the same network or reconfigure the Dyno.

### 14.3. Wi-Fi Operation

Issue	Solution
Test fails after starting it.	The router cache might be full, resulting in reduced bandwidth. Restart the router.
	Dyno might be receiving a weak signal. Make sure the Dyno is in an open area and the router is in of sight of the Dyno.
Test completes, but the data is missing packets, straight lines are visible across the graph or bad graph data is show.	The signal is unstable, or the router/application cache is full. Restart the application, router, and/or Dyno.
Unable to start a test, Dyno appears offline.	The IP address that is assigned to the Dyno by the router might have changed. Connect the USB cable, go to the Settings, select the proper com port and click on the Read Status button. If the Dyno is connected to the router, the application will update the IP address.

### 14.4. USB Configuration

Issue	Solution
Cannot change communication mode.	The com port number might be incorrect. Select the proper com port number and try again.

## 14.5. USB Operation

Issue	Solution
Test fails after starting it, lost data packets appear in the graph.	Windows USB driver is busy and cannot receive all the data coming from the Dyno. Close all unwanted programs on the computer, check if Windows updates are not running or an Antivirus is not making a scan, and try again.
Unable to start a test, Dyno appears offline.	The com port number for the Dyno assigned by Windows might have changed. Go to settings and select the proper com port number in the Dyno select on the area.
Test completes, but the data is missing packets, straight lines are visible across the graph or bad graph data is show.	The signal is unstable or the router/application cache is full. Restart the application, router, and/or Dyno.

## 14.6. Mechanical Failures

Issue	Solution
Dyno will not operate when attempting to start a test.	Make sure the red stop buttons are released prior to starting the test.
Shock keeps shifting/does not hold in place when running compression.	Make sure to insert both horizontal and vertical screws to secure it within the Dyno to hold it in place.
Dyno will not power on/communicate with software	Check if the power grid cable is compatible with the socket.
The device power switch does not light and the device does not start.	Unplug the power cable and change the fuse near the power switch. Fuse parameters: 5×20/10A.

## 14.7. LED Light Indicator

Light Color	Meaning
Orange	Dyno is starting up after power on, please wait.
White	Configuration is incomplete or the Wi-Fi network is not available. Follow the Software Setup section.
Red	The Emergency Stop button is engaged or the doors are open.
Blue	Dyno is connecting to the wireless network. Please wait.
Yellow	Dyno is ready for the operation.
Green	Operation in progress. Please wait until the operation completes.



**ATTENTION:** In case the issues persist, contact Laba7 support team for help.

## 15. Additional information

This section provides additional information related to conformity with the relevant Union harmonisation legislation:

- This equipment complies with the Radio Equipment Directive 2014/53/EU. This equipment contains a Raspberry Pi Compute Module 4 with an integrated RPI-RM0 radio module (Wi-Fi / Bluetooth). Operating frequency band: 2.4 GHz ISM band (2400–2483.5 MHz). The maximum radio-frequency output power transmitted in this band does not exceed 20 dBm (EIRP), in accordance with the applicable ETSI requirements.
- The crossed-out wheeled bin symbol with a solid bar shown on this equipment indicates that it must not be disposed of as unsorted municipal waste at the end of its life. It must be collected separately and sent for recycling in accordance with applicable WEEE regulations. For information on the return, collection and recycling of this product, please contact the manufacturer or your local supplier.
- LABA7 complies with the applicable obligations of the REACH Regulation (EC) No 1907/2006. If any component of this equipment contains a substance of very high concern (SVHC) in a concentration above 0.1 % w/w, information in accordance with REACH Article 33 will be provided on request.

## 16. Speed to load table

### Featherlight Dyno:

Featherlight (7.2 reduction, 3HP)					
Stroke (mm)	10	25	50	75	100
Max load (kg)	2357	941	470	314	235
Max speed (mm/sec)	196	490	983	1475	1966
Min speed (mm/sec)	5	9	17	25	34
Min frequency (Hz)	0.106				
Max frequency (Hz)	6.233				

### Light Dyno:

Light (7.8reduction, 4HP)							
Stroke (mm)	10	25	50	75	100	120	150
Max load (kg)	2670	1068	532	355	266	212	178
Max speed (mm/sec)	180	451	902	1351	1803	2167	2698
Min speed (mm/sec)	5	7	14	21	28	34	42
Min frequency (Hz)	0.087						
Max frequency (Hz)	5.71						

### MID Dyno:

MID (7.8reduction, 5.5HP)							
Stroke (mm)	10	25	50	75	100	120	150
Max load (kg)	3000	1714	858	569	428	342	285
Max speed (mm/sec)	180	453	905	1358	1812	2175	2718
Min speed (mm/sec)	5	7	14	21	27	33	41
Min frequency (Hz)	0.087						
Max frequency (Hz)	5.71						

**Heavy Dyno:**

HEAVY (7.0reduction, 10HP)							
Stroke (mm)	10	25	50	75	100	120	150
Max load (kg)	3000	3000	1485	991	743	594	496
Max speed (mm/sec)	201	503	1007	1511	2013	2416	3016
Min speed (mm/sec)	5	7	13	20	27	32	40
Min frequency (Hz)	0.085						
Max frequency (Hz)	6.403						

**Super Heavy Dyno:**

SUPER HEAVY (7.8reduction, 10HP)							
Stroke (mm)	10	25	50	75	100	120	150
Max load (kg)	3000	3000	2359	1565	1177	940	783
Max speed (mm/sec)	181	453	905	1358	1812	2175	2718
Min speed (mm/sec)	5	7	14	21	27	33	41
Min frequency (Hz)	0.087						
Max frequency (Hz)	5.71						

## 17. Warranty Information

LABA7 Shock Dyno is covered for 1 year of manufacturer warranty starting from the date of purchase, and it covers any manufacturer-related failures during that period.

### WHAT IS NOT COVERED

#### ALTERATION, MISUSE, OR ACCIDENT DAMAGE

Examples are:

- Failure to operate the device in accordance with the Owner's manual.
- Collision, fire, theft, freezing, vandalism, riot, explosion, or objects striking your device.
- Alteration of your device, including software programming or other components.
- Damage caused by improper maintenance or failure to follow the recommended maintenance schedule.

The repair of damages that are caused because parts or services used were not those prescribed in this manual's recommended maintenance schedule is not covered under warranty. It is the owner's responsibility to maintain the device as more fully set forth in and in accordance with the maintenance schedules outlined in this manual.

### MODIFICATIONS

Damage or performance problems resulting from modifications to your device are not covered under warranty.

Examples of modifications:

- Altering any mechanical parts or software programming.

The manufacturer is not responsible for any damages to the device during transportation. During accepting the shipment, please inspect the package for any visual damage. If the package is damaged, do not accept it.

## 18. Contact

If you have further questions about the product or need help with the installation, our technical staff will be happy to help you. Contact information can be found on our website [www.laba7.com](http://www.laba7.com).

**UAB LABA7**

**Address:** Giluzio st. 15 Vilnius LT-06253 Lithuania

**Email:** info@laba7.com

**Mobile phone:** +37065715336

Reprinting, even in extract, is allowed only after obtaining approval. We reserve the right to make changes to the product at any time if we consider them to be in the interest of quality improvement without prior notice or notification. Figures may be examples which may differ in appearance from the goods delivered. We also reserve the right to errors and cannot be held responsible for typographical mistakes. Our general terms and conditions apply.

# LABA7

## EU Declaration of Conformity

Date of Issue 2<sup>nd</sup> September 2021 Vilnius, Declaration Number 2021-09-02/01

**Name of the manufacturer:** LTD "LABA7"

**Address of the manufacturer:** Gilužio str. 15, LT-06239, Vilnius, Lithuania

**Contacts of the manufacturer:** info@laba7.com

**Object of the declaration:** Featherlight Shock Dyno

**Identification code of the object:** LBA2-00040

**Description of the object:** Featherlight Shock Dyno is the entry level shock dynamometer, which is based on scotch-yoke mechanism. Main specifications: velocity: up to 1 900 mm/s; maximum force: 10 000 N load cell; adjustable stroke: 25-50-75-100 mm; motor: 3 HP-220V electric motor; weight: 180 kg.

**Object of the declaration described above is in conformity with the relevant Union harmonisation legislation:**

- Machinery (MD) Directive 2006/42/EC
- Electromagnetic Compatibility (EMC) Directive 2014/30/EU
- Low voltage (LVD) Directive 2014/35/EU
- Radio Equipment (RED) Directive (2014/53/EU)
- Restricts hazardous substances in electrical and electronic components (RoHS) Directive 2011/65/EU

**References to the relevant harmonized standards used or references to the other technical specifications in relation to which conformity is declared:**

- EN IEC 61000-6-1:2019
- EN IEC 61000-6-2:2019
- EN IEC 61000-6-3:2021
- EN IEC 61000-6-4:2020
- EN IEC 61000-3-2:2019
- EN IEC 61000-3-3:2013
- ETSI EN 301 489-1:2019
- ETSI EN 301 489-17:2020
- IEC 60335-1:2020

**Additional information:** This declaration certifies compliance with the above-mentioned directives. This declaration of conformity is issued under the sole responsibility of the manufacturer. The technical documentation for the object of declaration is available from the manufacturer at the address above.

**Name and title of the manufacturers' representative:** Andrius Liškus  
CEO

**Signature of the manufacturers' representative:**



# LABA<sup>7</sup>

## EU Declaration of Conformity

Date of Issue 6<sup>th</sup> October 2020 Vilnius, Declaration Number 2020-10-06/01

**Name of the manufacturer:** LTD "LABA7"

**Address of the manufacturer:** Gilužio str. 15, LT-06239, Vilnius, Lithuania

**Contacts of the manufacturer:** info@laba7.com

**Object of the declaration:** Light Shock Dyno

**Identification code of the object:** LBA2-00034

**Description of the object:** Light Shock Dyno is a device for building, rebuilding, or tuning shocks and forks. It is perfect for testing MTB, road motorcycles, and road car suspensions. Main specifications: velocity: up to 2 500 mm/s; maximum force: 10 000 N load cell; adjustable stroke: 25-50-75-100-120-150 mm; motor: 4 HP-220V electric motor; weight: 260 kg.

**Object of the declaration described above is in conformity with the relevant Union harmonisation legislation:**

- Machinery (MD) Directive 2006/42/EC
- Electromagnetic Compatibility (EMC) Directive 2014/30/EU
- Low voltage (LVD) Directive 2014/35/EU
- Radio Equipment (RED) Directive (2014/53/EU)
- Restricts hazardous substances in electrical and electronic components (RoHS) Directive 2011/65/EU

**References to the relevant harmonized standards used or references to the other technical specifications in relation to which conformity is declared:**

- EN IEC 61000-6-1:2019
- EN IEC 61000-6-2:2019
- EN IEC 61000-6-3:2021
- EN IEC 61000-6-4:2020
- EN IEC 61000-3-2:2019
- EN IEC 61000-3-3:2013
- ETSI EN 301 489-1:2019
- ETSI EN 301 489-17:2020
- IEC 60335-1:2020

**Additional information:** This declaration certifies compliance with the above-mentioned directives. This declaration of conformity is issued under the sole responsibility of the manufacturer. The technical documentation for the object of declaration is available from the manufacturer at the address above.

**Name and title of the manufacturers' representative:** Andrius Liškus  
CEO –

**Signature of the manufacturers' representative:**



# LABA7

## EU Declaration of Conformity

Date of Issue 4<sup>th</sup> December 2019 Vilnius, Declaration Number 2019-12-04/01



<b>Name of the manufacturer:</b>	LTD "LABA7"
<b>Address of the manufacturer:</b>	Gilužio str. 15, LT-06239, Vilnius, Lithuania
<b>Contacts of the manufacturer:</b>	info@laba7.com
<b>Object of the declaration:</b>	Mid Shock Dyno
<b>Identification code of the object:</b>	LBA2-00011
<b>Description of the object:</b>	Mid Shock Dyno provides the best price-to-performance ratio. It is perfect for dirt track, motocross, and track car suspension servicing and tuning. Main specifications: velocity: up to 2 500 mm/s; maximum force: 15 000 N load cell; adjustable stroke: 25-50-75-100-120-150 mm; motor: 5.5 HP-380V electric motor; weight: ~ 430 kg.
<b>Object of the declaration described above is in conformity with the relevant Union harmonisation legislation:</b>	<ul style="list-style-type: none"><li>- Machinery (MD) Directive 2006/42/EC</li><li>- Electromagnetic Compatibility (EMC) Directive 2014/30/EU</li><li>- Low voltage (LVD) Directive 2014/35/EU</li><li>- Radio Equipment (RED) Directive (2014/53/EU)</li><li>- Restricts hazardous substances in electrical and electronic components (RoHS) Directive 2011/65/EU</li></ul>
<b>References to the relevant harmonized standards used or references to the other technical specifications in relation to which conformity is declared:</b>	<ul style="list-style-type: none"><li>- EN IEC 61000-6-1:2019</li><li>- EN IEC 61000-6-2:2019</li><li>- EN IEC 61000-6-3:2021</li><li>- EN IEC 61000-6-4:2020</li><li>- EN IEC 61000-3-2:2019</li><li>- EN IEC 61000-3-3:2013</li><li>- ETSI EN 301 489-1:2019</li><li>- ETSI EN 301 489-17:2020</li><li>- IEC 60335-1:2020</li></ul>
<b>Additional information:</b>	This declaration certifies compliance with the above-mentioned directives. This declaration of conformity is issued under the sole responsibility of the manufacturer. The technical documentation for the object of declaration is available from the manufacturer at the address above.
<b>Name and title of the manufacturers' representative:</b>	Andrius Liškus CEO —
<b>Signature of the manufacturers' representative:</b>	 —



# LABA7

## EU Declaration of Conformity

Date of Issue 8<sup>th</sup> July 2020 Vilnius, Declaration Number 2020-07-08/01

<b>Name of the manufacturer:</b>	LTD "LABA7"
<b>Address of the manufacturer:</b>	Gilužio str. 15, LT-06239, Vilnius, Lithuania
<b>Contacts of the manufacturer:</b>	info@laba7.com
<b>Object of the declaration:</b>	Heavy Shock Dyno
<b>Identification code of the object:</b>	LBA2-00027
<b>Description of the object:</b>	Heavy shock dyno is one of the powerful versions of LABA7 shock dynamometers. It can service any shock and fork but is best suited for off-road cars, 4X4s, trucks, or advanced motocross suspension work. Main specifications: velocity: up to 3 000 mm/s; maximum force: 15 000 N load cell; adjustable stroke: 25-50-75-100-120-150 mm; motor: 10 HP-380V electric motor; weight: ~430 kg.
<b>Object of the declaration described above is in conformity with the relevant Union harmonisation legislation:</b>	<ul style="list-style-type: none"><li>- Machinery (MD) Directive 2006/42/EC</li><li>- Electromagnetic Compatibility (EMC) Directive 2014/30/EU</li><li>- Low voltage (LVD) Directive 2014/35/EU</li><li>- Radio Equipment (RED) Directive (2014/53/EU)</li><li>- Restricts hazardous substances in electrical and electronic components (RoHS) Directive 2011/65/EU</li></ul>
<b>References to the relevant harmonized standards used or references to the other technical specifications in relation to which conformity is declared:</b>	<ul style="list-style-type: none"><li>- EN IEC 61000-6-1:2019</li><li>- EN IEC 61000-6-2:2019</li><li>- EN IEC 61000-6-3:2021</li><li>- EN IEC 61000-6-4:2020</li><li>- EN IEC 61000-3-2:2019</li><li>- EN IEC 61000-3-3:2013</li><li>- ETSI EN 301 489-1:2019</li><li>- ETSI EN 301 489-17:2020</li><li>- IEC 60335-1:2020</li></ul>
<b>Additional information:</b>	This declaration certifies compliance with the above-mentioned directives. This declaration of conformity is issued under the sole responsibility of the manufacturer. The technical documentation for the object of declaration is available from the manufacturer at the address above.
<b>Name and title of the manufacturers' representative:</b>	Andrius Liškus CEO
<b>Signature of the manufacturers' representative:</b>	 

# LABA7

## EU Declaration of Conformity

Date of Issue 2<sup>nd</sup> September 2023 Vilnius, Declaration Number 2023-09-02/01

<b>Name of the manufacturer:</b>	LTD "LABA7"
<b>Address of the manufacturer:</b>	Gilužio str. 15, LT-06239, Vilnius, Lithuania
<b>Contacts of the manufacturer:</b>	info@laba7.com
<b>Object of the declaration:</b>	Super Heavy Shock Dyno
<b>Identification code of the object:</b>	LBA2-00038
<b>Description of the object:</b>	Super heavy shock dyno is the most powerful version of LABA7 shock dynamometers. It can service any shock and fork but is best suited for off-road cars, 4X4s, trucks, or advanced motocross suspension work. Main specifications: velocity: up to 3 000 mm/s; maximum force: 20 000 N load cell; adjustable stroke: 25-50-75-100-120-150 mm; motor: 15 HP-380V electric motor; weight: ~430 kg.
<b>Object of the declaration described above is in conformity with the relevant Union harmonisation legislation:</b>	<ul style="list-style-type: none"><li>– Machinery (MD) Directive 2006/42/EC</li><li>– Electromagnetic Compatibility (EMC) Directive 2014/30/EU</li><li>– Low voltage (LVD) Directive 2014/35/EU</li><li>– Radio Equipment (RED) Directive (2014/53/EU)</li><li>– Restricts hazardous substances in electrical and electronic components (RoHS) Directive 2011/65/EU</li></ul>
<b>References to the relevant harmonized standards used or references to the other technical specifications in relation to which conformity is declared:</b>	<ul style="list-style-type: none"><li>– EN IEC 61000-6-1:2019</li><li>– EN IEC 61000-6-2:2019</li><li>– EN IEC 61000-6-3:2021</li><li>– EN IEC 61000-6-4:2020</li><li>– EN IEC 61000-3-2:2019</li><li>– EN IEC 61000-3-3:2013</li><li>– ETSI EN 301 489-1:2019</li><li>– ETSI EN 301 489-17:2020</li><li>– IEC 60335-1:2020</li></ul>
<b>Additional information:</b>	This declaration certifies compliance with the above-mentioned directives. This declaration of conformity is issued under the sole responsibility of the manufacturer. The technical documentation for the object of declaration is available from the manufacturer at the address above.
<b>Name and title of the manufacturers' representative:</b>	Andrius Liškus CEO
<b>Signature of the manufacturers' representative:</b>	